

# AUTOFAB

*Offroad Trucks*

PERFORMANCE PRODUCTS  
CATALOG



Since 1977

10996 North Woodside Ave. Santee California 92071

[www.autofab.com](http://www.autofab.com)

619-562-1740

Established in 1977, **AUTOFAB** stands for **AUTO**motive **FAB**rication. Our experience includes completing racing vehicles for many areas of motorsport such as the tough Baja 1000, rallies, drag racing, and circle track. We also specialize in off-road race car preparation, custom pre-runners as well as engine conversions of all types.

This catalog contains a list of the products from **AUTOFAB** that we thought were necessary and hard to find. If you don't see something you are looking for or need assistance, please call **(619) 562-1740** or write:



10996 Woodside Ave. N. • Santee, CA 92071

- TERMS:** Orders up to \$200.00 may be sent C.O.D. paid with a money order or pre-approved check. {Personal checks must include a current address, phone number and Drivers License} Returned checks are subject to a \$20.00 fee. Orders between \$200.00 to \$2000.00 must be paid with cashiers check, Visa, Mastercard, American Express, or Discover Card before shipping out. Handling fees apply to all shipments.
- FREIGHT:** Most orders are packaged and shipped within 48 hour via UPS, with the exception of special order items and/or large quantity orders. Fiberglass and some kits are sent by truck, freight, prepaid or freight collect. A Box fee will be added to all large freights. No drop shipping.
- CLAIMS:** Title to merchandise passes to buyer on delivery through any common carrier, including UPS. Delivery of the merchandise in good condition to the buyer is the responsibility of the carrier, and all claims must be made with the carrier immediately upon discovery.
- RETURNS:** No returns on special order items, this includes fiberglass, coils, shocks etc. Any exchanges must be made within 30 days of purchase and with original receipt. All merchandise returned for reasons other than warranty claims will be subject to a 20% restocking fee.
- LIMITED WARRANTY:** Every attempt has been made by Autofab to manufacture the finest products available. All Autofab manufactured merchandise is warranted to be free from defects in materials and workmanship for a period of 90 days from date of purchase. Our liability is limited to repair or replacement of a defective product.
- HOW TO ORDER:** Always order by part number {when available}; include any information which might help ensure that we ship you the parts you need, i.e., year make of vehicle, engine size, transmission type, 2 or 4 wheel vehicle. When calling in an order please be sure to leave a current phone number. All dealer orders should be faxed to 619-562-6151 rather then calling in orders when ever possible. Foreign orders must be paid in US currency.
- SPECIAL ORDER ITEMS:** A 50% None Refundable deposit is required on all special order items and order over \$1000.00 will have to be paid in full with a cashiers check before processing the order. No refunds or exchanges on any special order item.
- CORE FEES:** Cores must be returned in clean, good working condition within 30 days of purchase. Bushing replacement is charged, if needed after the return of cores and all cores are subject to a 20% handling fee.
- DEALER INQUIRIES:** Dealer pricing is based on an established good business relationship and quantity orders only, with proof of business license and resale. For more information please contact us at 619-562-1740.



**Autofab Extra Wide Bronco/F150**  
 wide track 4wd  
 6 inch wider hub to hub with 20plus inches  
 wheel travel capability.  
 Equal length tie rod steering system  
 Radius arms with rod ends  
 Twin Traction beams with monoballs  
 Beams reinforced , skid plate included  
 Wider rear end available



**Autofab Extra Wide Ranger 4x4**  
 Model 44 conversion  
 F150 track width when completed (8" wider)  
 20" plus wheel travel capabilities  
 Equal length tie rod steering system  
 Rear bed kit with 18 inch wheel travel  
 Radius arms with rod ends  
 Beams reinforced and monoballs installed  
 Skid plate included.  
 Wider rear end available



## \* 1982 Autofab Ford Bronco \*



16" Front  
wheel travel  
\*  
4" suspension  
Lift  
No Drop Down  
Lift Brackets!  
\*  
16" to 18" Rear  
wheel travel



Originally a 1982 Ford Bronco

1996 Grill using Autofab fiberglass fenders, hood , and rear quarter panel  
16 inches of front wheel travel , custom shock mounts , 4 inches suspension lift  
Hood mounts with our unique polymer hood pin kits and stock hinges

Front fenders bolt on with our fender mounting kit

Rear quarter panels shown mounted with aircraft dzus fasteners or use  
our brand new Fender mounting kits.

Fiberglass tailgate with operational rear window, 50 lbs. lighter and No Rust!



2.5 Sway Away kit above / 2 shocks per wheel

- ◆ FH-203 Fiberglass hood with hinge mount inner panel
- ◆ FF-203 Bolt on fiberglass fenders
- ◆ FTK-150-4wd Front 16 inch wheel travel kit
- ◆ HPMK-82 Weld on structure for hood pins
- ◆ FMK-150 Tubular fender mounting kit
- ◆ CAK-150 Coil adjuster kits
- ◆ CI-191705 Coil spring compression inserts ( 3 )
- ◆ SKID-44 Bolt on front diff housing skid plate
- ◆ FBK-150 Front bumper kit
- ◆ FSP-150 Aluminum skid plate for front bumper
- ◆ TG-Bronco Fiberglass tailgate 1978 to 1993

- ◆ Custom fabricated coil buckets with shock hoops and removable crossbar over the engine
- ◆ Setups available for Fox, Bilstein, Sway Away, King shocks
- ◆ Heavy duty limit straps to protect the shocks from topping out at full stretch
- ◆ Tubular race quality radius arms available with bushings or optional heim ends
- ◆ Trick Coil Spring adjusters for ride height adjustments. Allows you to fine tune the ride height of each front wheel.
- ◆ Custom radius arm pivot brackets for better tire clearance (12:50 X 35 mudders on 15 x 7 inch alloy wheels shown)
- ◆ Coil spring compression inserts available for extra heavy duty use offroad (helps the coils last longer)



10996 N. Woodside Ave.  
Santee California 92071



619-562-1740  
www.autofab.com

## \* Bronco Rear Travel Kit \*

- 16" Rear Wheel Travel using stock spring mounting
- Custom Progressive leaf spring packs
- 3 shocks per wheel custom bolt in crossmembers
- Custom lower shock brackets locate on existing mounts
- 2 Link kits designed to control spring wrap up on power and cycle correctly for full travel .
- Eliminates spring fatigue, sagging and breaking, common when using softer spring packs.

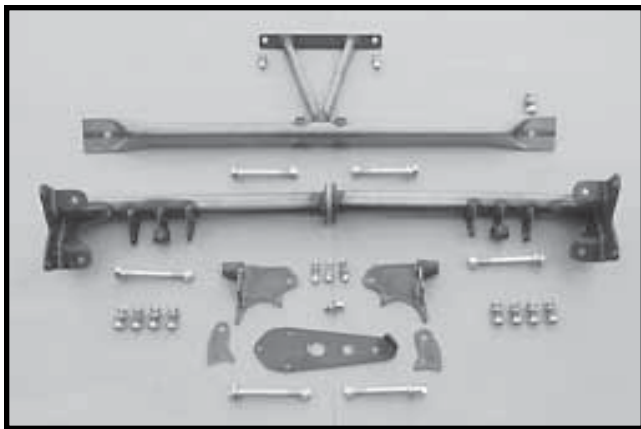

- CBS-150 Custom rear springs by National Spring
- BR-2link Rear anti-wrapup 2 Link Kit
- RSM-150 Rear shock mount crossmembers with lower brackets that locate to existing shock mounts
- DOM-900 9" Ford housing with DOM axle tubes installed and new bearing ends
- SKID-900 Trick fitting skid plate for 9" diffs , bolts on to the pinion support and tabs welded in back.
- BS-306 Fiberglass rear quarter panel with gas door provisions available
- TG-Bronco Fiberglass tailgate, Lighter, No Rust!
- LS-150 Limit Straps ( included in kit )

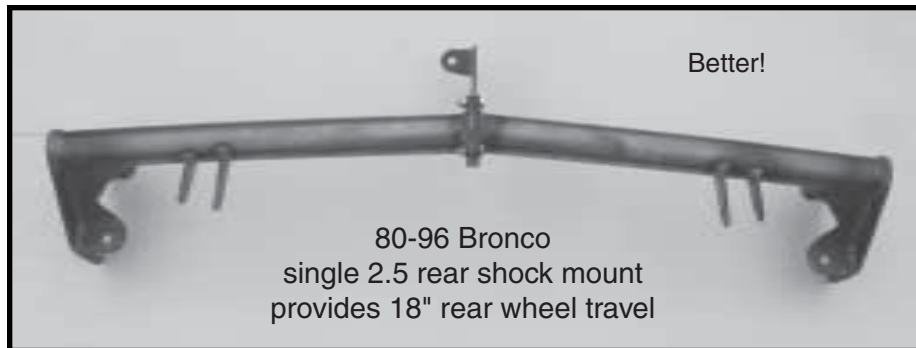

Basic 4 inch lift foundation  
complete with hiems and monoballs  
perfect starting point for coil overs



9 inch Ford skid plate for  
vital protection of 9"case

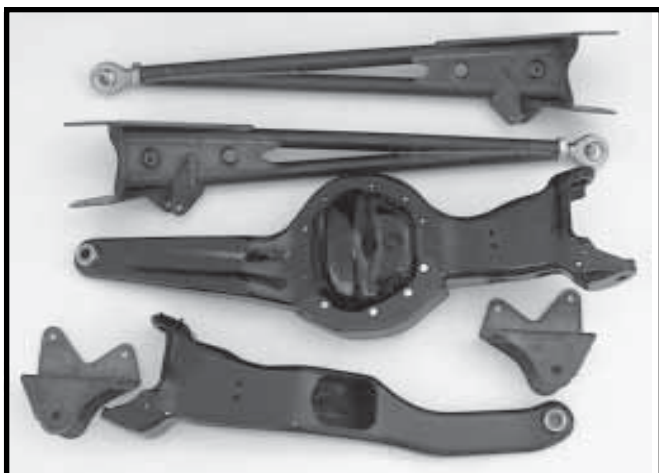

Above picture is an 86 Bronco with front and rear travel kits installed. Tires are 12.50 X 33's with good fender clearance. This is basically what my Bronco looked like before fiberglass body parts and 35 inch tires were added



\* 1965 -79 Ford 2wd 16" Front wheel travel \*

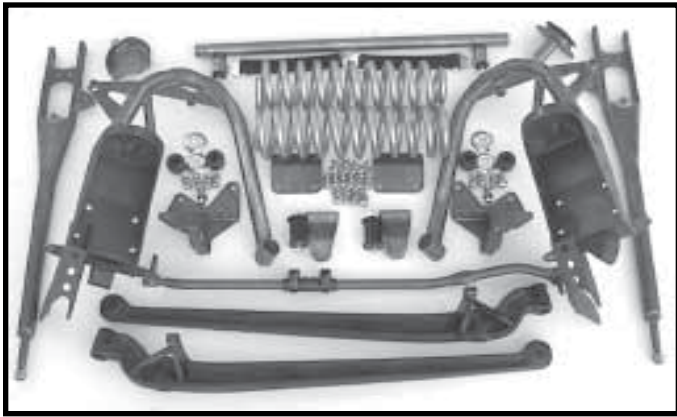

1970 F350 16 inch wheel travel kit

Right photo  
1970 F250 2wd with  
16" wheel travel kit  
Fox Racing Shocks  
shown with  
FF-102 front  
fiberglass fenders  
and  
FH-100 Hood



1973 F100 wheel travel kit

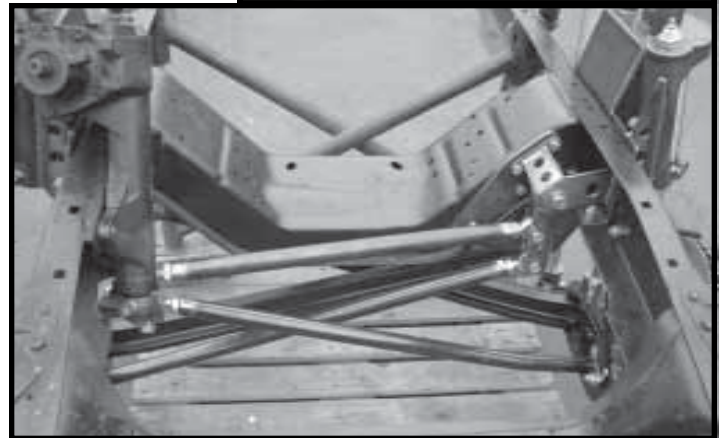

Autofab equal length tie rod system for serious off road use. Virtually eliminates the nasty bump steer of the left side wheel due to the short tie rod. This particular system has 19 inches of wheel travel. With coil over shocks properly mounted up to 26 inches wheel travel possible using Autofab pivots and stock one ton beams. Stock steering will not allow wheel travel over 16 inches.

1975 white F100 spare parts truck front end featured on Autofab.com website. 19 inches wheel travel with equal length tie rod system.

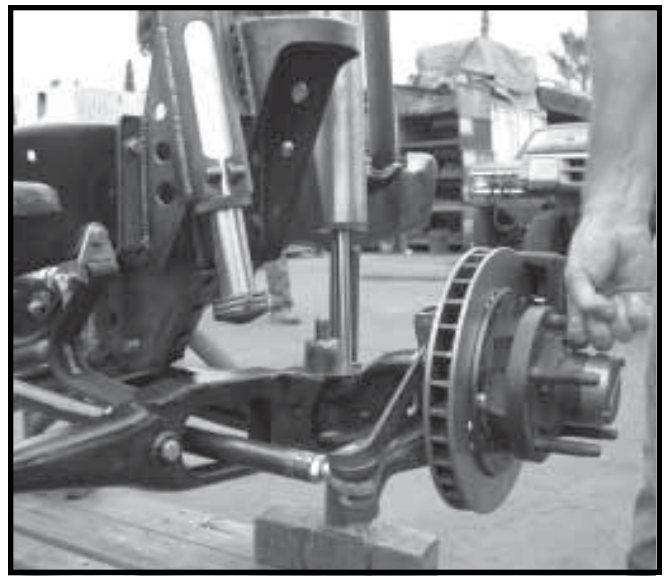
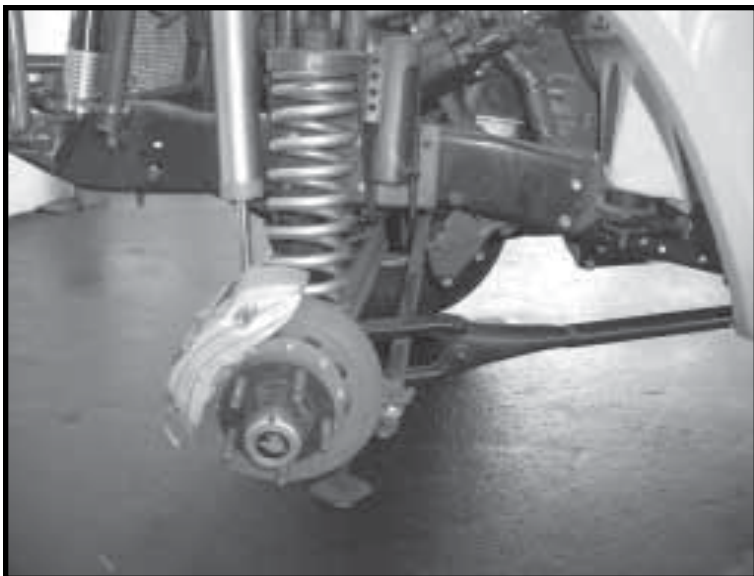

10996 N. Woodside Ave.  
Santee California 92071



619-562-1740  
www.autofab.com



**65-79 Ford Full Size Truck Two Link System**

Our two link systems are designed to keep the rear end in line, prevent spring wrap and eliminate pinion angle changes under power.

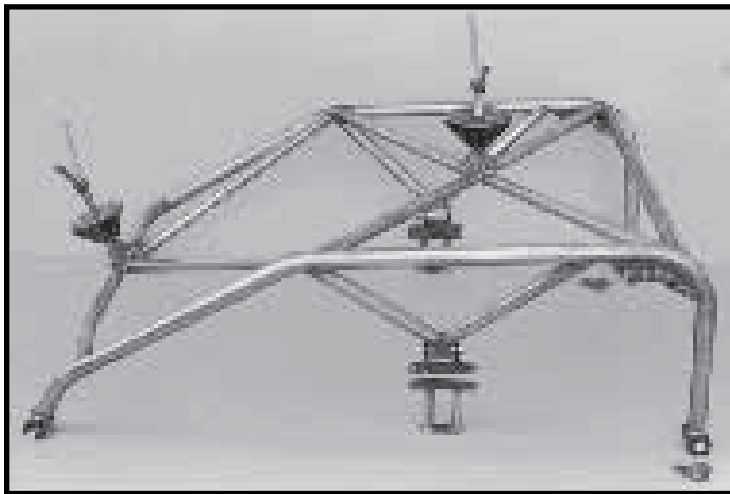

Right pictures show the 1977 Black prerunner with our raised lip old school front fenders, Drop center hood and rear bedsides. I put 34,000 hard miles on this truck before a mild rollover put her out of commission. And I used regular 31 splineflanged axles in a heavy duty 9" housing with a 460 engine.

Are you going to coil over your early Ford front end? use the Autofab beam pivot brackets shown below. Bolt on design relocates the beam for a 2 inch wider track width.

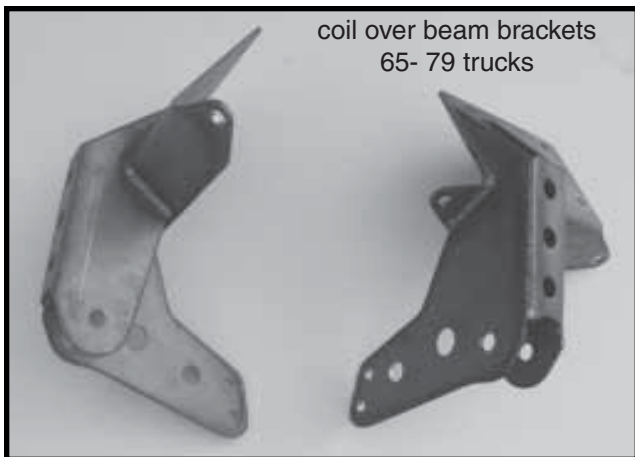

coil over beam brackets  
65- 79 trucks

**\* F100 Rear 18" Travel \***



This rear kit was designed to use long travel shocks and stroke 18" of wheel travel with the use of progressive rate spring packs. 2 spare tire mounts optional. For the enthusiast that wants to keep the bed floor we make the rear structure without the x's and tire mounts. (see ranger section page 11)



10996 N. Woodside Ave.  
Santee California 92071



619-562-1740  
www.autofab.com



**2000 F350**  
 Super Duty  
 4 wheel drive

Bolt On !  
 performance  
**SWAY A WAY**  
**RaceRunner**  
 shocks with  
 nitrogen reservoirs

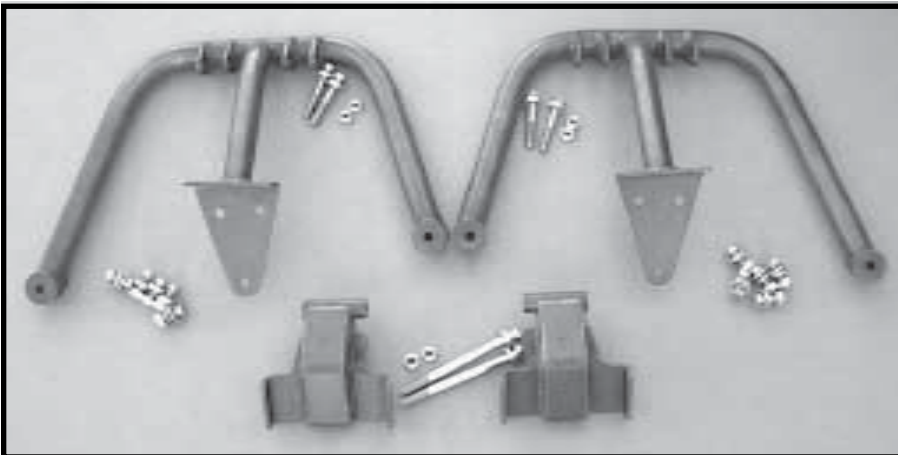
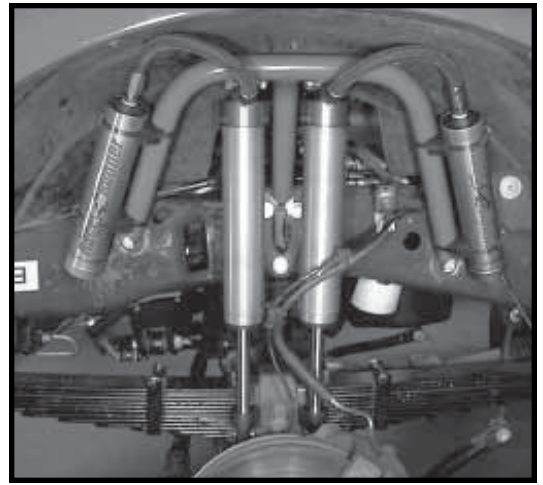

Features Custom Autofab HD  
 shock mounts  
 Sway A Way 2.5" reservoir  
 shocks  
 25 percent increase in front wheel  
 travel !

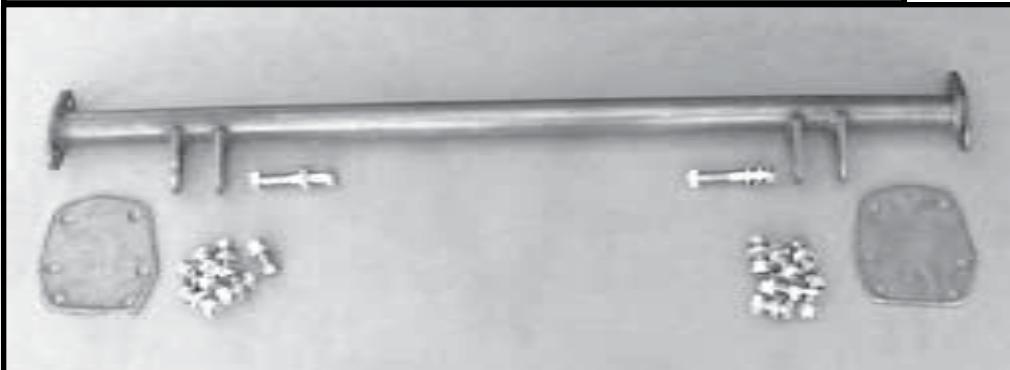

Autofab  
 Rear upper shock mount  
 Quality DOM tube cross-  
 member  
 with captured style shock  
 mts.  
 1/4" steel mounting plates  
 and shock tabs for super  
 duty.  
 Grade 8 hardware supplied  
 1/2" bolts for shock and  
 bracket mounting

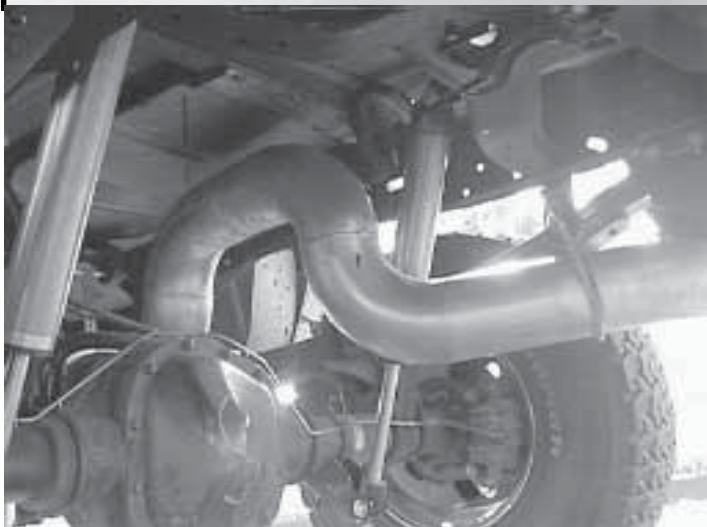

10996 N. Woodside Ave.  
 Santee California 92071



619-562-1740  
[www.autofab.com](http://www.autofab.com)



## Super Duty Track Bar Repair

Stock factory brackets below broke off from severe use and lifts with track bar length incorrect. Autofab solution is a heavy duty replacement kit and adjustable track bar. Replacement kit right shown with optional stabilizer shock mount added. The basic kit is fabricated from 2-1/4" thick plates formed to sandwich each other and bolt under the factory spring mounting plate. Ford's solution is to replace the entire housing! Autofab kit saves the expense of replacing the housing and provides a better than stock solution.

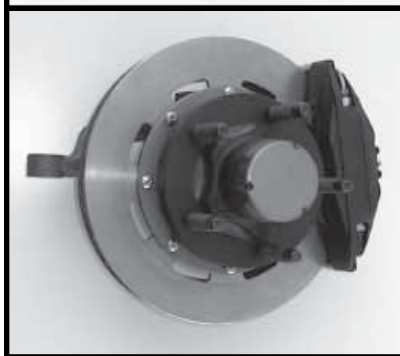
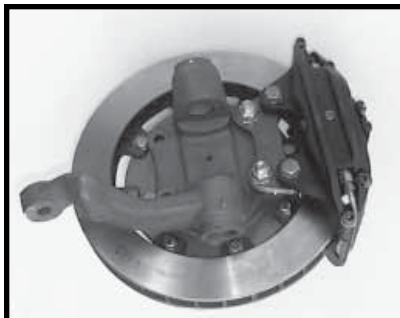
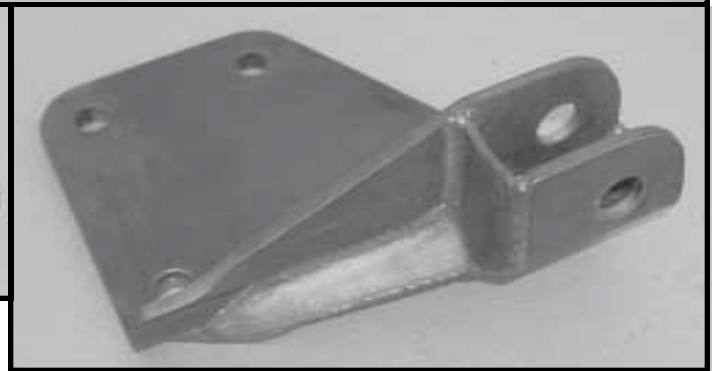
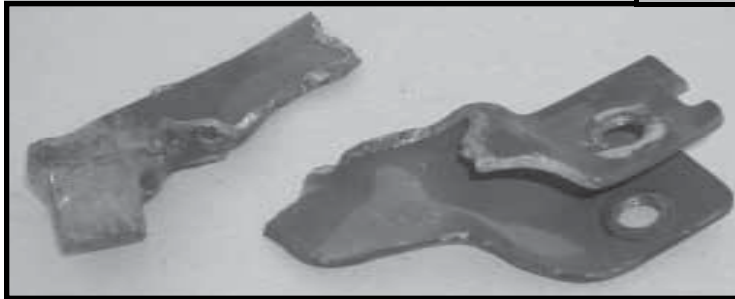
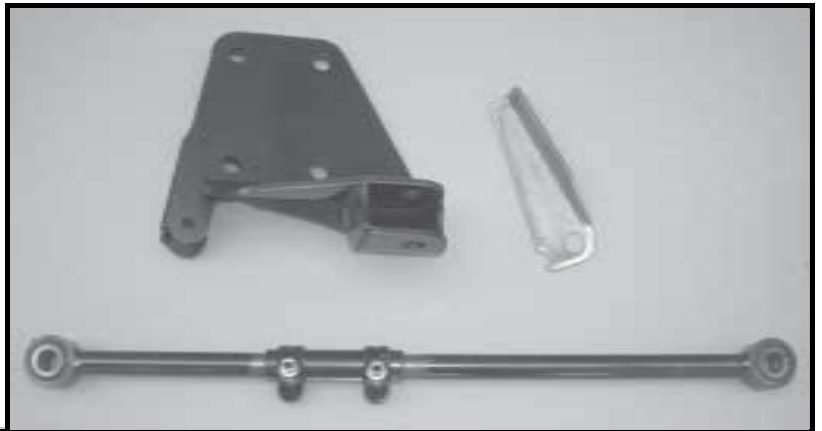

### Autofab Hubs for one ton spindles

Set up your Ford with one ton beams and spindles and get the 5 on 5 1/2 half ton bolt pattern. Comes with new bearings, seal, dust cover, 5.8 studs and rotor adaptor. We can supply setups with Willwood brakes, our hubs are made by Cone Industries



### Cone Ind. Ball joints

Perfect for custom A arm applications  
90 degrees angle capabilities

### CONE Ind.

Hubs , Rotors, and Spindles for Ranger 2wd use with 83-88 forged beams comes with 5/8" wheel studs preferred setup for Class 7S



### Cone spindles

modified with, 300M bearing supports larger wheel bearings, and Willwood caliper brackets

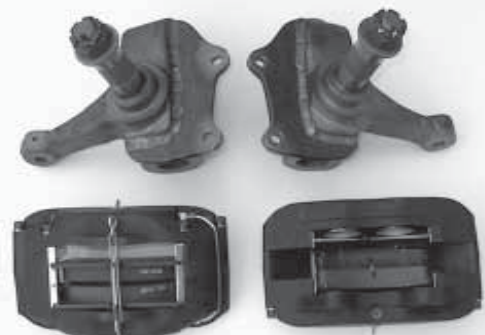

10996 N. Woodside Ave.  
Santee California 92071



619-562-1740  
www.autofab.com

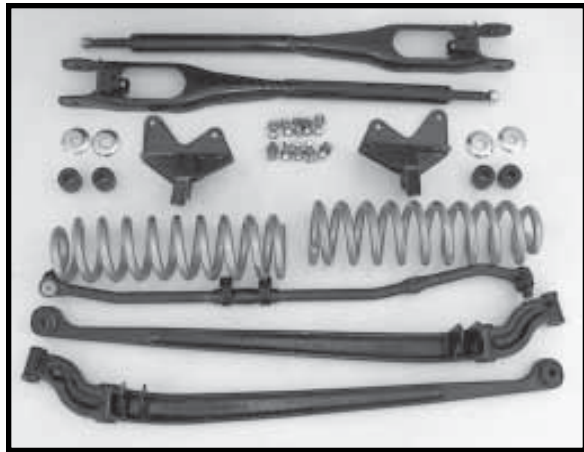

65-79 Ford 2WD 5" Lift

## 65-79 FORD 2WD TRUCK 5" LIFT

This kit is designed to give that "race look" for those who do not want the expense of the long travel system. It features our adjustable drag link which solves the problem of fine tuning the steering gear center on early Ford trucks. Extended radius arms and pivot brackets provide positive caster and better load angles on the pivot bushings. Stock coil towers and shock mounts are maintained. Beams are straightened first and then aligned for the 5" lift. Our radius arms are lengthened with solid steel first, then welded with tubing over the extension for looks. The threaded end is a new machined part.

Options include: Double shock mounts

New king pins if you send your spindles in.

\*Core charges on beams and radius arms or send your parts.



First two F250's shown with 5" lift package.

Flatbed truck on the bottom shown with the 3" econo lift using stock length radius arms.



65-79 Ford 2WD econo 3" Lift shown with double shock option



10996 N. Woodside Ave.  
Santee California 92071



619-562-1740  
www.autofab.com



**89-97 Ford Ranger 2WD 4" Econo Lift**



**97 Ranger 2wd with 4 inch econo lift  
Tire size 10.50x15, 31" tall**

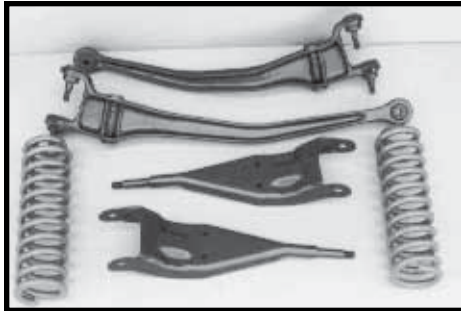

**83-88 Ford Ranger 2WD 4" Econo Lift**



pivot bracket for 2wd Ranger  
use when taking out a drop  
down lift kit.

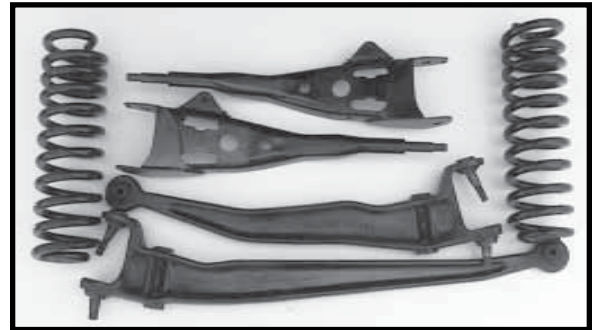

**82-86 F150 2wd econo lift**



**1995 F150 2wd truck with 4 inch econo lift.  
Rear is stock height  
Tire size 12.50x33 on original Ford rims**

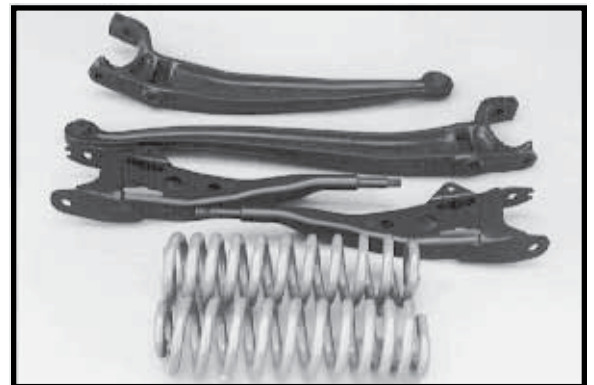

**87-96 F150 2wd econo lift**



**1988 Ford  
Bronco II  
2 Wheel  
Drive  
4" Lift  
Tubular  
Radius Arm  
Package  
Middle Road  
Kit**



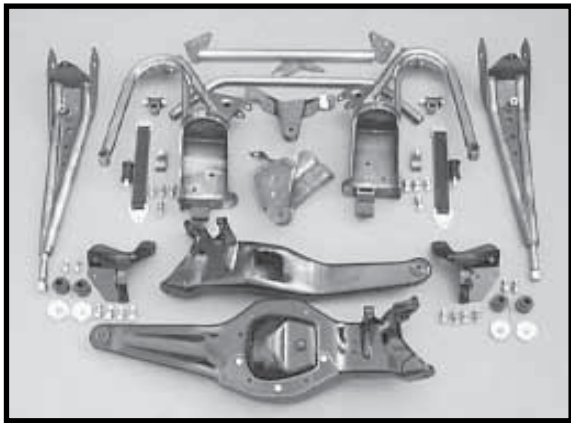

**\* Ranger-Explorer 4WD Model 35 wheel travel kit \***

- Tubular race style radius arms and fabricated pivots
- Custom coil buckets with welded shock mounts
- Grade 8 mounting hardware for all frame mounting
- Limit straps and bump stops included
- Modified beam housings exchange for your good parts
- Front differential skid plate reinforcement included
- Reworked beam pivot bracket exchange for your good one
- Crossmember components between radius arm pivots
- Removable engine crossbar between shock hoops
- Ball heim joints for radius arms and beams available
- A complete bolt in kit no welding to frame !

Custom Tubular radius arms and pivot brackets are important features of our wheel travel kits. They allow for maximum droop of the beams and 16" wheel travel. Highly reinforced and good looking, the only arm that offers exclusive 3 point mounting to the 4WD housing with high strength design that is completely bolt on

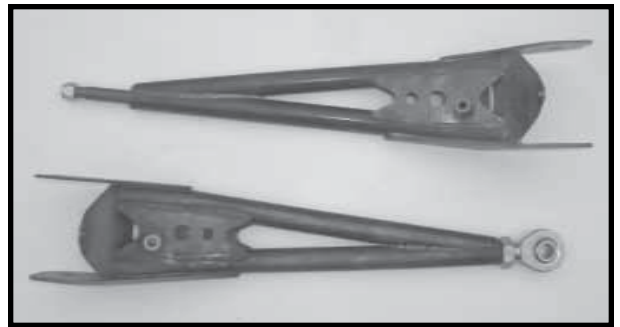

**\* Ranger 4WD mdl 28 wheel travel kit 1983 to 1991 \***

- 16" Front wheel travel with 4" suspension lift
- Race style radius arms and custom pivot brackets
- Optional ball heim mounting , extra \$ of course
- Front diff skid plate included with travel kits
- Complete bolt on mounting to all frame connections
- Grade 8 hardware provided for bracketry to frame mtg.
- Limit straps and bump stops provided with travel kits
- Up to 3 shock mounting per wheel
- Works with factory air conditioning

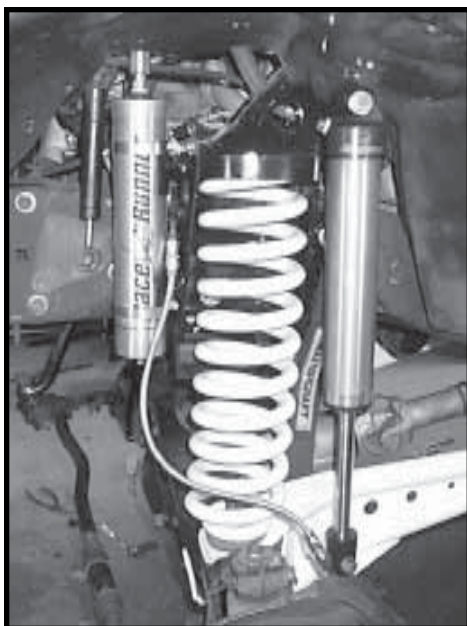
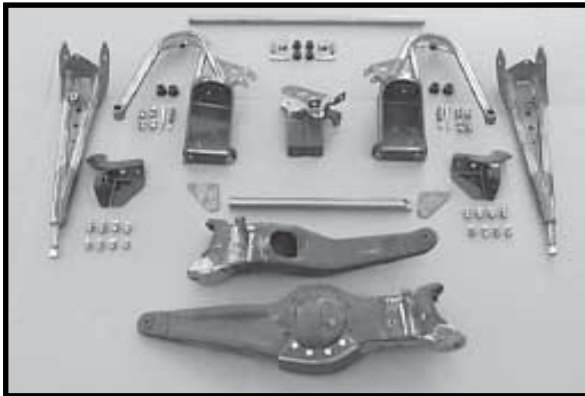

**16" wheel travel  
single 2.5"  
Racerunner shock  
per wheel**

**Coil bucket comes with res-  
ervoir brackets and shock  
mounts**

**Coil adjusters optional**

**This travel kit is much  
easier to install and still of-  
fers excellent wheel travel  
and performance!**

**16 inch wheel travel Model 28  
kit installed  
2 Bilstein racing shocks per  
side**



10996 N. Woodside Ave.  
Santee California 92071



619-562-1740  
www.autofab.com



## 1985 Ford Ranger

4 Wheel Drive

\* *featuring* \*  
Autofab Front and  
Rear Travel kits  
*and*  
Conversion fiberglass  
to the 1997 Grill



16" Front wheel travel  
2 Bilstein racing shocks per wheel  
Stock housings modified for lift  
Stock axles and hubs used  
Differential skid plate  
Conversion fiberglass  
Custom front bumper grill guard  
3/16" aluminum skid plate



Autofab lifts and wheel travel kits feature excellent steering geometry because we modify the housings for proper alignment.  
The handling is better and we offer the most ground clearance by design.  
Remember ! Autofab has been doing this since 1977  
Quality is worth the cost.

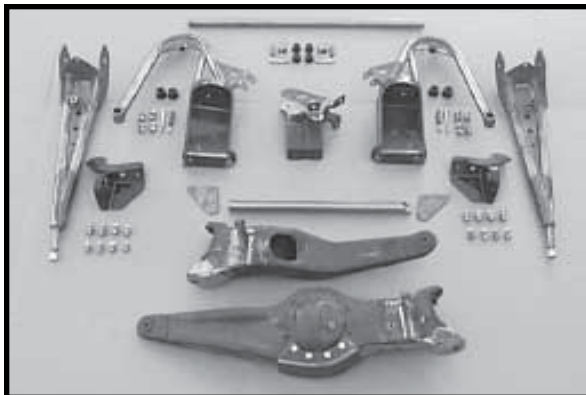

Grade 8 Bolts high strength lock nuts  
New Bushings  
bump stops  
limit straps  
skid plate  
crossmember parts for over the motor and between the rear pivot brackets

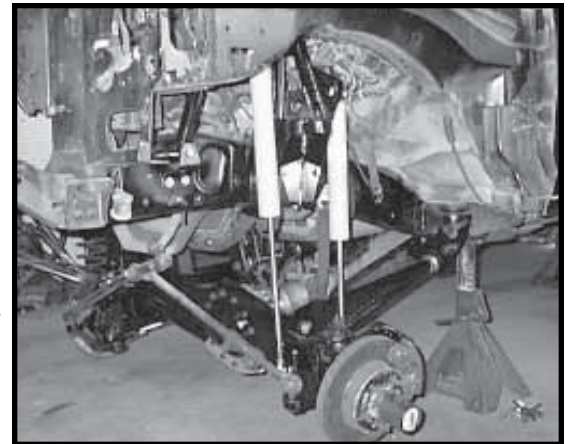

83-92 Ranger conversion fiberglass to new grill  
RF107 - Flared front fenders  
RH 107 - Custom hood with hinge panel

Mdl28 TK - for the model 28 early 4x4  
Mdl35 TK - for the model 35 later (90 up)  
model 35 front end kits will work on Explorer too

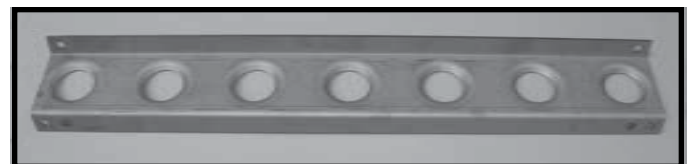

Rear crossmember for all Ranger beam type trucks Replace that ugly Ford unit with the Autofab RXC100

### Ranger Rear Travel Kit

18" rear wheel travel  
custom offroad springs, autofab 2 link wrap-up bars  
up to 3 shocks per wheel, 6 bushing bracket kits for bolt-in frame and bump stop reinforcement included



10996 N. Woodside Ave.  
Santee California 92071



619-562-1740  
www.autofab.com



**Ranger 4x4 mdl 35 Four inch lift**

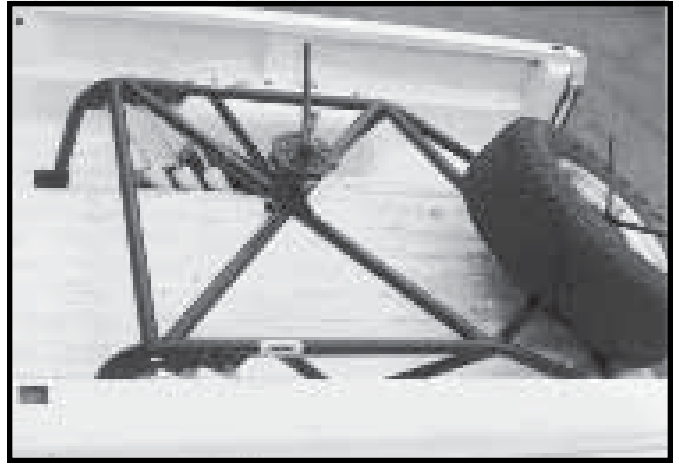

**Ford Ranger Short Bed 18" Rear Wheel Travel  
Rear bed kit with 2 tire mounts**

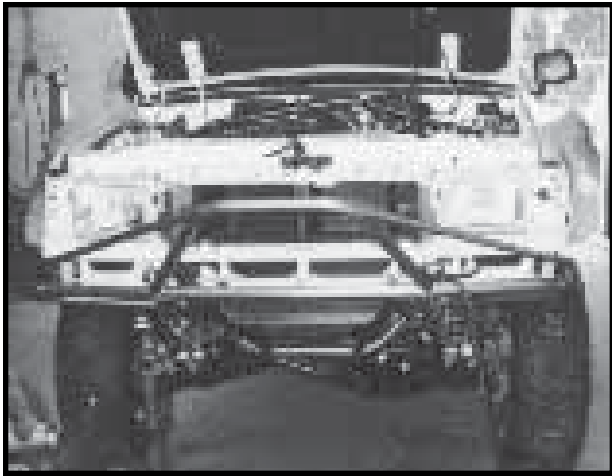

**1994 Ranger 4x4  
16" front wheel travel kit  
Custom front bumper kit**

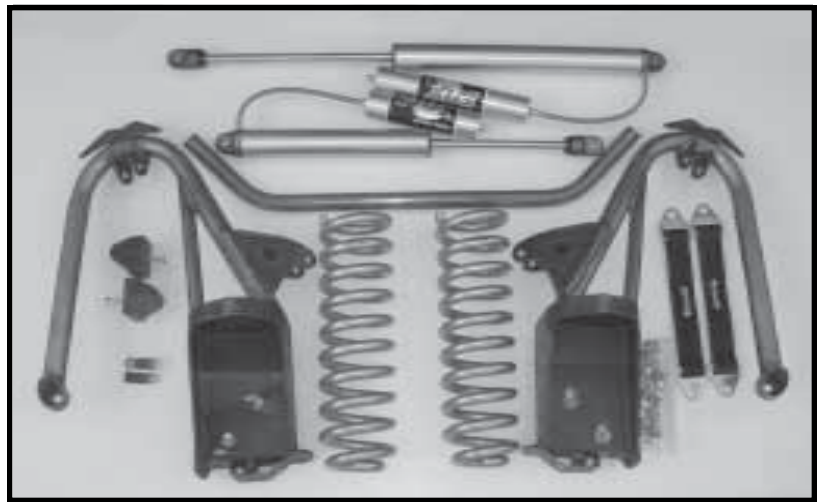

**Custom coil buckets, shock hoop structure**  
Optional coil adjusters, Shock brackets  
Crosstube over the motor, 4 inch coil springs  
Bump stops, Autofab limit straps, Fox Racing shocks

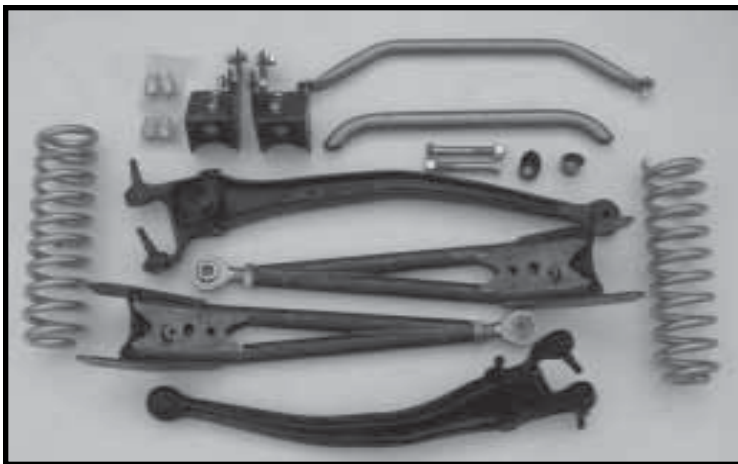

**2wd Ranger 16" wheel travel kit**  
Custom radius arms, Matching pivot brackets  
Special lower shock mounts, 2 cross members  
Pivot bushing kit, Grade 8 mounting hardware  
4 inch bent beams, Optional Heim joint arms



10996 N. Woodside Ave.  
Santee California 92071



619-562-1740  
www.autofab.com



2.0 bump stop



2.5 bump stop



2.0 remote reservoir



2.5 remote reservoir

3.0 remote reservoir

2.0 coil over

2.5 coil over



### Fox Racing Shocks

These competition style take-apart shocks are an excellent choice for pre-runner and racing applications. Available in travel

**lengths of 5"stroke to 18"stroke**

- Complete with reservoirs
  - Variety of valving settings
  - Monotube design
  - Readily available parts
  - very competitively priced
- Air shocks and bump stops  
American made

2.5 triple bypass shock



3.0 triple bypass shock



#### Top left to right

2.0 air bump stop

2.5 air bump stop

2.0 remote reservoir racing shock

2.5 remote reservoir racing shock

#### Above:

3.0 remote reservoir racing shock

2.0 Coil over shock remote reservoir

2.5 coil over shock piggy back style reservoir

#### Right:

2.5 triple bypass shock w/piggyback reservoir

3.0 triple bypass shock w/piggyback reservoir



10996 N. Woodside Ave.  
Santee California 92071



619-562-1740  
www.autofab.com



Autofab battery trays for Optima profile fit to the rounded shape of the spiral wound style Optima batteries.



BT-200

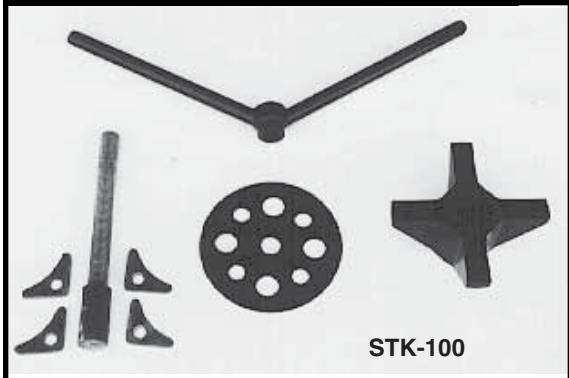

STK-100

Spare tire handle kit with urethane hub for wheel protection.

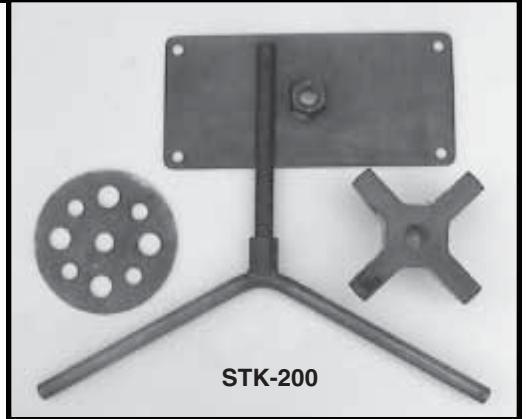

STK-200

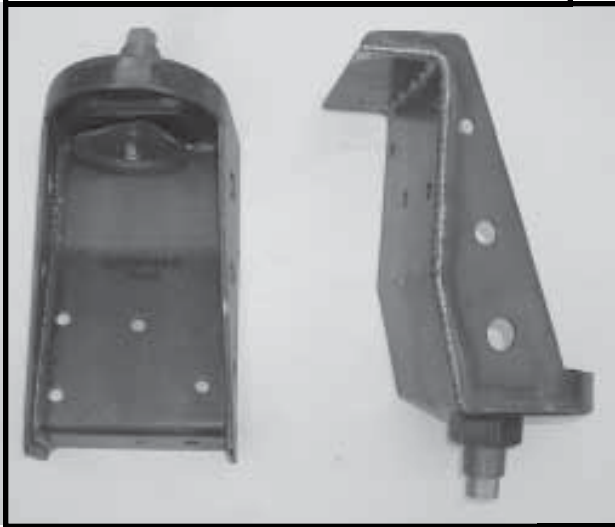

Bronco/F150 coil buckets shown with coil adjusters

- CB150- bare buckets
- CB150/W CA- with coil adjusters
- CA150- coil adjuster kits
- RB2wd-Ranger coil bucket 2wd truck
- RB4wd- Ranger coil bucket 4wd truck
- RB2wd/WCA- with coil adjuster
- RB4wd/WCA- with coil adjuster
- RCA100- coil adjuster kit

Shackles

Ranger, F150, Bronco stock length and 1" longer  
Heavy duty custom made with bushings.  
Order by application



- Heims, regular steel econo rod ends
- 3/4L or 3/4R- for left and right
  - 5/8L, 5/8R, 1/2L, 1/2R, 3/8LR
  - 5/16LR and 1/4LR
  - 3/4WB- weld bung 1"OD
  - 5/8WB- weld bung 1"OD
  - 1/2WB- weld bung 3/4"OD
  - 3/8WB- weld bung 1/2"OD
  - 3/4HS- heim spacer 1/2" bolt
  - 5/8HS- heim spacer 1/2"bolt
  - High Angle spacers
  - 3/4HAS- for 1/2"bolt
  - 5/8"HAS- for 1/2"bolt
  - all spacers priced individual
  - 2 needed per heim



10996 N. Woodside Ave.  
Santee California 92071



619-562-1740  
www.autofab.com





**83-92 Ranger Bumper kit - #RB-8392**

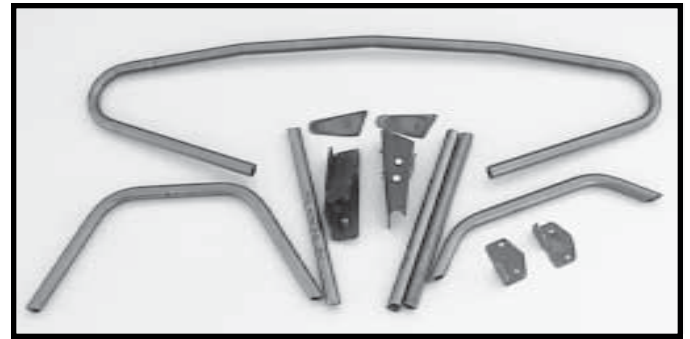

**93-97 Ranger Bumper Kit - #RB-9397**

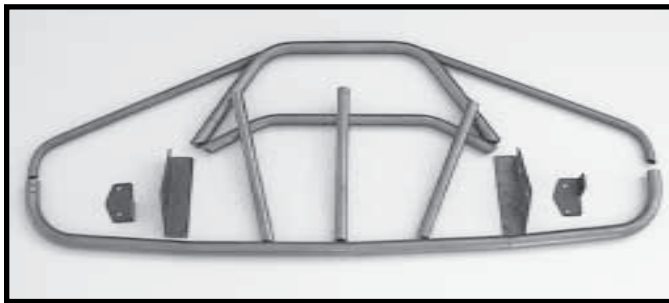

**87-91 F150-Bronco Bumper kit FB-8791**



**92-96 F150-Bronco Bumper Kit - #FB-9296**  
*Use for 80 to 91 trucks when upgrading to 96 grill*



**Below: Winters shifters**

We stock most applications of shifter. This is the preferred shifter of off road racing. Positive gate allows for precise gear change without jumping a gear.



**1985 Ranger longbed setup with our front bumper kit and fiberglass drop center hood** (RH-101), flared front fenders (RF-104), and our longbed fiberglass bedsides (BS-201). Suspension front and rear and you will have an awesome prerunner starting with an inexpensive common truck.

Front fenders easily bolt on to original mounting. Bedsides require removal of existing sheetmetal sides and bolting our panels on. Hood swings on stock hinges with 2 of our HP-100 urethane hood pin kits mounted to the stock radiator support.

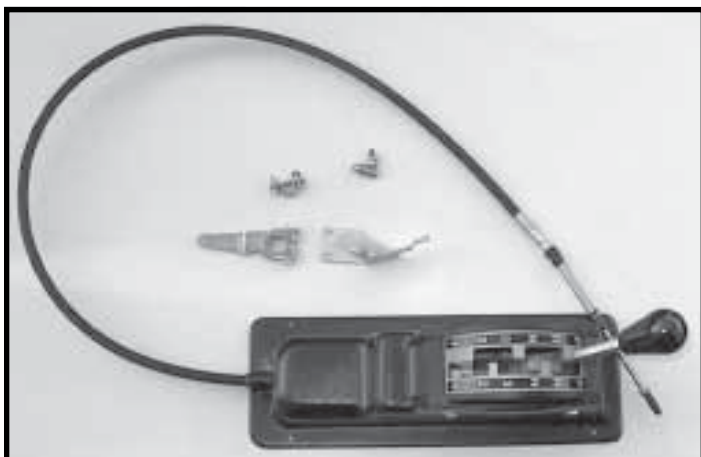

10996 N. Woodside Ave.  
 Santee California 92071



619-562-1740  
[www.autofab.com](http://www.autofab.com)



1988-97 Chevy  
Cowl Hood  
CH105  
and  
Autofab  
front fenders  
CF106



Part#	Make	Year	Part	Style
CH-100	Chev Truck	73-80	Hood	Stock
CH-101	Chev Truck	81-87	Hood	Stock
CH-102*	Chev Truck	73-80	Hood	Dropped Center
CH-103*	Chev Truck	68-72	Hood	Dropped Center
CH-104*	Chev Truck	81-87	Hood	Dropped Center
CH-105*	Chev Truck	88-97	Hood	Cowl Induction Scoop <b>NEW!</b>
EH-100*	El Camino	70-72	Hood	Cowl Induction Style
EH-101	El Camino	65	Hood	With Cowl Induction Scoop
EF-101	El Camino	64	Fender	Large wheel opening with flare
EB-101	El Camino	64-65	Bedsides	Bulged with bigger opening
CF-100	Chev Truck	81-87	Fender	Stock appearing, no modifications
CF-101	Chev Truck	73-80	Fender	Bulged 3" , larger wheel opening
CF-102	Chev Truck	81-87	Fender	Bulged 3" , new aero design
CHF-103	Chev Truck/Conv	73-87	Fender/Hood	Converts to 88-up (Race mounting only) Fender raised 3" Bulged 2 1/2", full length hood with cowl panel
CF-104	Chev Truck	88-up	Fender	Old Vessels Style, raised 3", bulged 4"
CF-105	Chev Truck	88-up	Fender	Ragland Style, raised 6", bulged 8"
CF-106	Chev Truck	88-97	Fender	Bulged 3", Bigger wheel opening, aero style
CF-107	Chev Truck	81-87	Fender	Bulged 5", Big wheel opening for 37"+ tires <b>NEW!</b>
CF-108	Chev Truck	73-80	Fender	Bulged 5", Big wheel opening for 37"+ tires <b>NEW!</b>
SH-100	Chev S-10	82-94	Hood	Full length, cowl included race mounting only
SH-101	Chev S-10	82-94	Hood	Stock, Race mounting only
SF-100	Chev S-10	82-94	Fender	Raised 2 1/2", Flared 2", Bolt on
SF-101	Chev S-10	82-94	Fender	Stadium style works with SH-100, race mounting
CR-100	Chev Truck	All Stepsides	Rear Fender	3/4 size & bobbed (mini truck style)
CR-101	Chev Truck	All Stepsides	Rear Fender	Bobbed full size
CR-102	Chev Truck	All Stepsides	Rear Fender	Stock full size

\* Available with inner bracing to allow stock hood hinges to be used. Hood pins must be used to secure the front of the hood (See page 34), the latch can no longer be used. Specify when ordering.  
**NOTE:** Chevy fenders require custom mounting, stock core, support/grill assembly must be braced.

CF108 73-80 chevy 5 inch bulge



CF-101 73-80 chevy 3 inch bulge



10996 N. Woodside Ave.  
Santee California 92071



619-562-1740  
www.autofab.com



**65 Ford front and rear all fiberglass  
see stepsides on page 20**



**FIBERGLASS**

**FH-90 & FF-90**

Part No.	Make/Model	Years	Part	Style
BS-500	Chev Truck	88-up	Bedside	Ragland style sportside, large wheel opening, short bed
BS-501	Chev Truck	88-up	Bedside	Stock style, 3"larger wheel opening - No bulge
BS-502	Chev Truck	73-87	Bedside	Bulged, flared, and larger wheel opening for 37" tires
MF-100	Mitsubishi/D-50	79-86	Fender	3"Larger Wheel Opening, race mounting only, 2" flare
MH-101	Mitsubishi V8	2000up	Hood	Stock appearing light weight replacement (race mtg only)
MF-101	Mitsubishi V8	2000 up	Fender	Bulged 2.5", 3" larger wheel opening
FH-90*	Ford Truck	65-66	Hood	Dropped Center Robbie Gordon style*
FH-95*	Ford Truck	65-66	Hood	Stock*
FH-100	Ford Truck	67-72	Hood	Stock*
FH-103*	Ford Truck	67-72	Hood	Sloped ( 2 1/2" removed from the front tapered to the rear)
FH-101*	Ford Truck	73-79	Hood	Dropped Center
FH-102	Ford Truck	73-79	Hood	Stock
FH-200	Ford Truck	80-86	Hood	Stock
FH-201*	Ford Truck	80-86	Hood	Dropped Center
FH-202*	Ford Truck	87-up	Hood	Dropped Center
FH-203*	Ford Truck	92-96	Hood	Stock
FH-204	Ford Truck	92-96	Hood	Full length w/cowl panel, race
FH-205*	Ford Truck	87-91	Hood	Stock
FF-90*	Ford Truck	65-66	Fender	Raised 2 1/2", 2" flare
FF-100*	Ford Truck	73-79	Fender	Raised 2 1/2", no flare
FF-101*	Ford Truck	67-72	Fender	Stock
FF-102*	Ford Truck	67-72	Fender	Raised 2 1/2", no flare
FF-103*	Ford Truck	73-79	Fender	Raised 3 and bulged 3 inches New
FF-104*	Ford Truck	67-72	Fender	Bulged 3.5" and raised 3"

\* Available as bolt-on parts; hoods can accept stock hinges, fenders bolt onto stock inner fenders using stock mounting hardware. Hood pins must be used to secure the front of the hood (See page 38), the hood latch will not be used.  
NOTE: 80 and newer Fords require bracing of the core support.

**1973-79 shortbed sides  
front fenders and drop center hood**

**FH-100, FF-102 and Shortbed Stepside Glass**



10996 N. Woodside Ave.  
Santee California 92071



619-562-1740  
www.autofab.com



Chris Wilson Bronco with FF205 front fenders and a FH-203 4 pin mounted hood.

Vosburg bronco with FF-202 fenders 16" wheel travel kit with Fox shocks

Part No.	Make/Model	Years	Part	Style
FF 200	Ford Truck	80-86	Fender	Raised 3"
FF 202	Ford Truck	87-91	Fender	Raised 3", bulged 2 1/2" Dave Shoppe style
FF 203	Ford Truck	92-96	Fender	Dave Ashley Style, 4" larger opening, 3" flare
FF 204	Ford Truck	92-96	Fender	Vessels style, 4.5" larger opening, 5" flare
FF 205	Ford Truck	92-96	Fender	Raised 4", stock appearing, no bulge, 1" flare added
FF 206	Ford Truck	80-86	Fender	Ashley style bulged 4 x 3 New
FF207	Ford Truck	87-91	Fender	Ashley style bulged 4 x 3 New
FR 100	Ford Truck	56-79	R.Fender	Bobbed, stepside fender
FR 101	Ford Truck	56-79	R.Fender	1 1/2" wider, stepside fender, stock length
FR 102	Ford Truck	56-79	R.Fender	Stock, stepside fender
BS 100	Ford, Chevy	56-87	Stepside	Bedside only, Short Bed, Fender not included, flat top
BS 300	Ford Truck	67-72	Bedside	Shortbed fleetside, stock
BS 301	Ford Truck	80-96	Bedside	Shortbed fleetside, stock
BS 302	Ford Truck	80-96	Bedside	Ashley style fleetside, raised 4" & bulged 3", shortbed
BS 303	Ford Truck	80-96	Bedside	Vessels style, raised 4" & bulged 6" shortbed
BS 304	Ford Truck	80-96	Flareside	Some Flare, larger wheel opening, bottom rear tapers up
BS 305	Ford Truck	73-79	Bedside	Short bed fleetside, 3" bigger wheel opening, bulged 2"
BS 306	Bronco	80-96	Bedside	Rear quarter panel matches Ashley front fenders
BS 307	Ford Truck	67-72	Bedside	Longbed sides with 3" larger wheel opening, no bulge
BS 308	Ford Bronco	78-79	Bedside	Stock replacement bedside w or w/o taillight section
BS 309	Ford Bronco	78-79	Bedside	Bulged 3.5" and 3 inch larger wheel opening
DS 100	Ford Truck	80-96	Door Skin	Stock door skin only

Vessels Style FH-204 and FF-204 BS-303 shortbed sides

1978-9 Bronco sides stock left rear shown



10996 N. Woodside Ave.  
Santee California 92071



619-562-1740  
www.autofab.com



RF-104



RF-103

Part No.	Make/Model	Years	Part	Style
CS 100	Ford Truck	80-96	Cabside	Stock door skin inc. rear quarter and front window pillar
RS 100	Ford Truck	80-96	Roof	Duplicate of stock roof skin
CM-100	Courier/Mazda	77-82	Hood	Stock
CM-101	Courier/Mazda	72-76	Hood	Scoop
RH-100	Ranger/Bronco II	82-88	Hood	Stock
RH-101	Ranger/Bronco II	82-88	Hood	Dropped Center
RH-102	Ranger/Bronco II	89-92	Hood	Stock
RH-103	Ranger/Bronco II	89-92	Hood	Dropped Center
RH-104	Ranger	93-97	Hood	Full length w/cowl panel race mounting only
RH-105	Ranger	93-97	Hood	Stock
RF-100	Ranger/Bronco II	82-88	Fender	Stock
RF-101	Ranger/Bronco II	82-88	Fender	Raised 2 1/2"
RF-102*	Ranger/Bronco II	89-92	Fender	Raised 2 1/2" with 1 1/2" flare
RF-103*	Ranger/Bronco II	89-92	Fender	Raised 2 1/2", bulged 2"
RF-104*	Ranger/Bronco II	82-88	Fender	Raised 2 1/2", bulged 4"
RF-105*	Ranger	93-97	Fender	Raised 2 1/2", stock style, 1" extra flare
RF-106*	Ranger	93-97	Fender	Raised 3", bulged 4"—full race style
RF-107*	Ranger	83-92	Fender	Raised 3" bulged 3"- conversion to 97 grill
RF-108*	Ranger	98 up	Fender	Raised 3" bulged 4"
BS-200	Ranger	82-92	Bedside	Shortbed, 3" larger wheel opening- No bulge
BS-201	Ranger	82-92	Bedside	Longbed, raised 3 1/2", bulged 3"
BS-202	Ranger	93-97	Bedside	Shortbed, raised 3 1/2", bulged 5"
BS-203	Ranger	93-97	Bedside	Longbed, raised 3 1/2", bulged 4"

\* Available as bolt-on parts; hood bolts on to stock hinges, Fenders bolt on to stock inner fenders using stock mounting hardware. Hood pins must be used to secure the front of the hood, the latch can no longer be used. See page 1.

**RF-106**

This truck has our 4" middle of the road lift, 12:50 x 33 " tires on 15 x 7 alloy wheels, rear sides have been pushed out.



RH-104 and RF-105



10996 N. Woodside Ave.  
Santee California 92071



619-562-1740  
www.autofab.com



RF-108 bulged fenders 1998up Ranger

Left  
67-72  
Ford  
bulged  
New!



FH-100, FF-102 and Shortbed Stepside Glass



RF-106 and RH-104

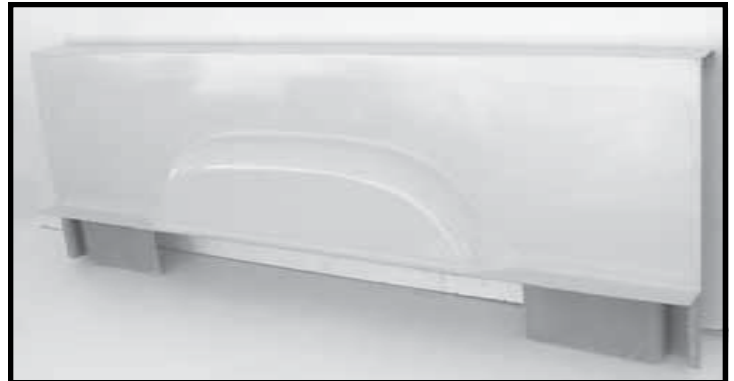

BS100 Stepsides

RF-102 and RH-103



10996 N. Woodside Ave.  
Santee California 92071



619-562-1740  
www.autofab.com



**Bronco side after removing outer skin.**

Note dzus mtg. tabs are traced and cut out of the original bed skins. Drill the holes and bend to fit new bedsides



**BS-306 fiberglass sides installed**

Large Captive Dzus' securely mounts fiberglass panels  
Optional provisions for stock gas tank door shown!



**TG-Bronco: fiberglass tailgate**

Weighs about 50 lbs less than stock metal tailgate  
"Fiberglass will not rust "



**TG-Bronco: inside view window in**

Fully functional with inside structures to mount motor  
Tailgate is light enough to eliminate springs that add weight

**1973-87 Chevy Truck Fiberglass**

Bedsides are flared out about 5" with a larger wheel well  
They will fit all shortbed trucks from 73-87  
Front fenders and drop center hood are designed for the 81-87 style truck grill ,  
Front end will also work on 88-91 Blazer and Suburban



10996 N. Woodside Ave.  
Santee California 92071



619-562-1740  
www.autofab.com

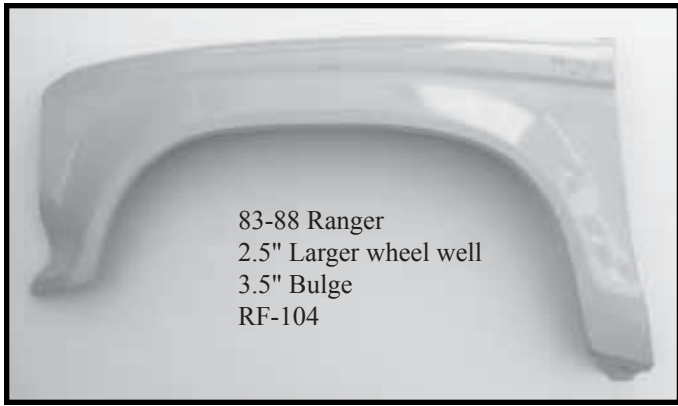

83-88 Ranger  
2.5" Larger wheel well  
3.5" Bulge  
RF-104

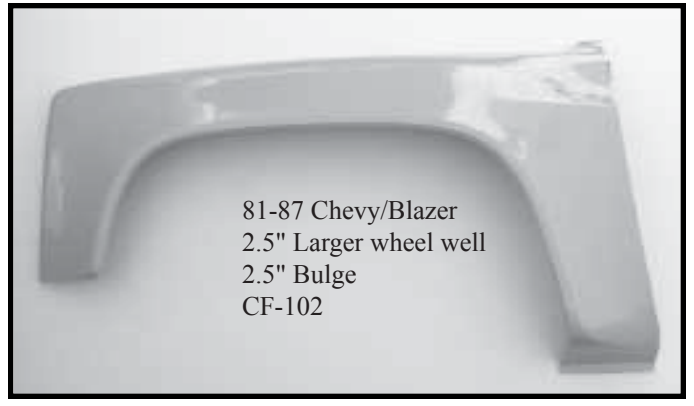

81-87 Chevy/Blazer  
2.5" Larger wheel well  
2.5" Bulge  
CF-102

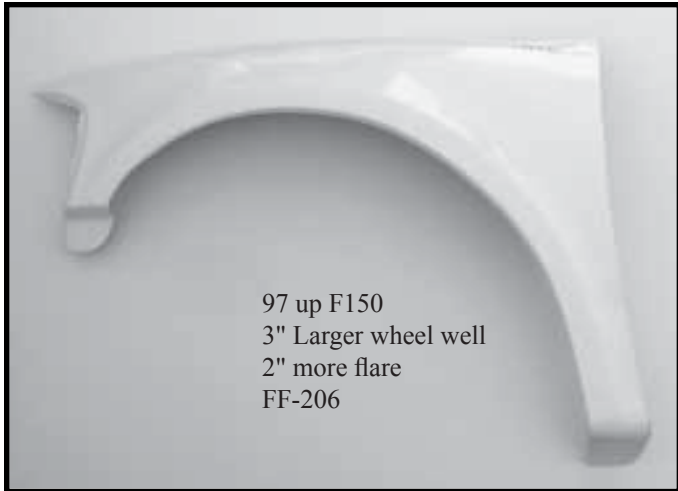

97 up F150  
3" Larger wheel well  
2" more flare  
FF-206



88-97 Chevy Truck  
2.5 " Larger wheel well  
3.5" Bulge  
CF-106

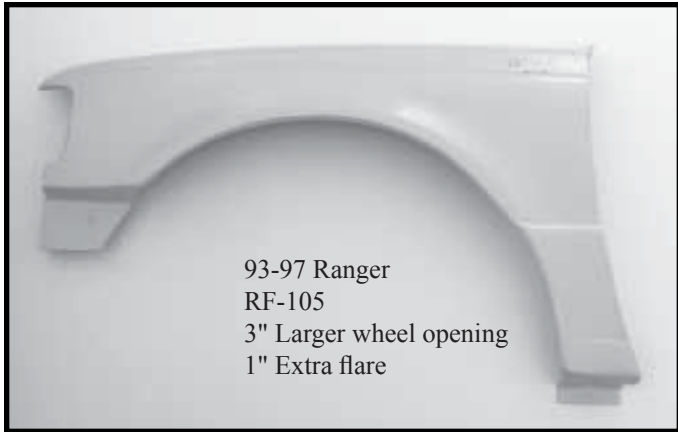

93-97 Ranger  
RF-105  
3" Larger wheel opening  
1" Extra flare

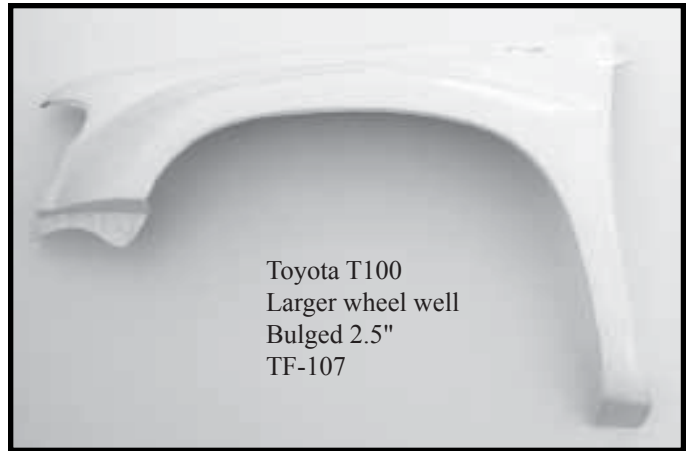

Toyota T100  
Larger wheel well  
Bulged 2.5"  
TF-107

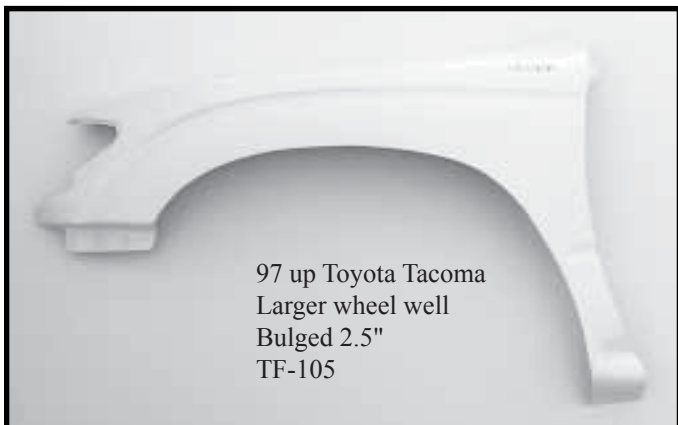

97 up Toyota Tacoma  
Larger wheel well  
Bulged 2.5"  
TF-105



F100 56-79  
1.5" Wider  
FR-101





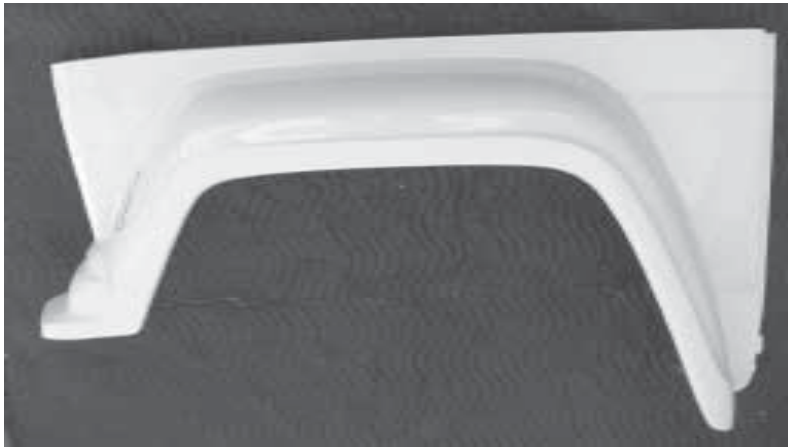

**JF-201 honcho/wagon**



**NF-100 nissan hard body**

Part No.	Make/Model	Years	Part	Style
JH-100	Jeep Truck/Wagoneer	74-up	Hood	Stock
JF-201	J10 Truck/Wagoneer	74-up	Fender	Raised 2" and flared out 2", will bolt on (NEW)
JH-101	Cherokee/Comanche	84-93	Hood	Stock style, race mounting only
JF-100	Cherokee/Comanche	84-93	Fender	Raised 1 1/2", works with stock hood
JF-101	Cherokee/Comanche	84-93	Fender	Raised 2" , bulged 2 1/2" , use stock hood (NEW)
JF-102	Cherokee/Comanche	84-93	Fender	2" longer, 5" bulge, requires matching hood, stadium style
JF-103	Cherokee/Comanche	84-93	Fender	Large wheel opening, 10" bulge requires grill modifications, matching hood
JS-100	Cherokee/Comanche	84-93	Bedside flare	Add on 8" flare
NH-100	Nissan Hardbody	86 -up	Hood	Stock, race mounting only
NF-100	Nissan Hardbody	86 -up	Fenders	Bulged 3", larger opening
NS-100	Nissan Hardbody	86 -up	Bedside	Dually appearance, bulged, race mounting only
TH-100	Toyota Truck	79-83	Hood	Scoop, Race mounting only
TH-101	Toyota Truck	84-88	Hood	Stock
TF-101	Toyota Truck	79-83	Fender	Stock 4WD type
TF-102	Toyota Truck	84-88	Fender	Larger opening, flared 2"
TF-103*	Toyota Truck	84-88	Fender	Ivan Stewart, large opening, large bulge, must run hood also
TF-104	Toyota Truck	89-93	Fender	Larger opening, bulged 2"
TS-103*	Toyota Truck	84-88	Bedside	Ivan Stewart, large opening, bulged
TS-105	Toyota Truck	89-93	Bedside	Short bed, bigger wheel opening, bulged
LH-100	ChevLuv/Isuzu	81-up	Hood	Stock
LH-101	ChevLuv/Isuzu	72-80	Hood	Scoop
LF-100	ChevLuv/Isuzu	72-80	Fender	Raised 2 1/2" & Flared

**Ivan Stewart Style TS-103**



**Ivan Stewart Style TS-103 and TF-103 with hood**



10996 N. Woodside Ave.  
Santee California 92071



619-562-1740  
www.autofab.com

# Fuel Safe Racing Cells

Approved for use by: FIA,  
SCCA, SCORE, SODA, and  
NHRA racing associations

The new Fuel Safe Enduro Cell combines aircraft technology with superior formulated polymer materials to meet FIA-FT3 approval at an economy price. Enduro cells come with full foam baffling, aircraft style nut ring , gasket , pickup up assembly , standard fill plate , rollover check valve and a 5 year warranty !

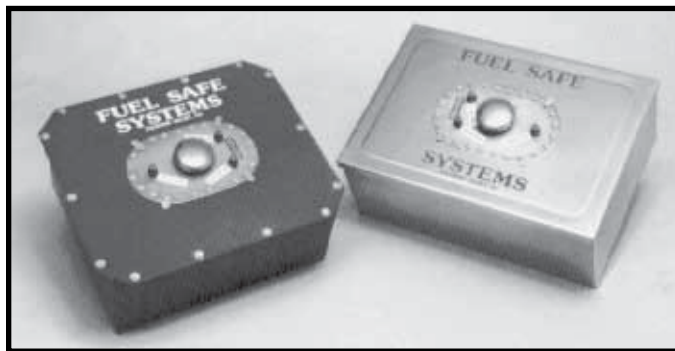

## Enduro Racing Fuel Cells

<u>STANDARD EQUIPMENT</u>	<u>Volume</u>	<u>PART #</u>	<u>LENGTH</u>	<u>WIDTH</u>	<u>HEIGHT</u>
	5 gal	ED105	13-1/2"	13-1/2"	8-1/4"
• Full foam baffling	8 gal	ED108	20-1/2"	15-3/8"	7-7/8"
• Single 3/8 or 1/2 in. pickup and one 1/2 in. vent check valve fitting	12 gal	ED112	20-3/8"	17-5/8"	9-3/8"
• Internal fuel strainer	15 gal	ED115	25-1/2"	17-5/8"	9-3/8"
• 3 in. Standard fill plate with rollover valve built in.	22 gal	ED122A	33-5/8"	17-5/8"	9-1/4"
• Steel Container	22 gal	ED122B	24-1/2"	16-5/8"	13-3/8"
	25 gal	ED125	25-1/2"	17-3/8"	14-1/4"
	32 gal	ED132A	33-3/4"	17-1/2"	14-3/8"
	32 gal	ED132B	25-1/2"	17-3/8"	18-1/4"

## Custom Fuel Cells

- Available any size with custom shapes
- Available complete with an aluminum container
- Single or dual fill plate options
- Sending units to match most gauges
- optional larger vent valves for quick fill
- Fax us a drawing or blueprint for a quotation

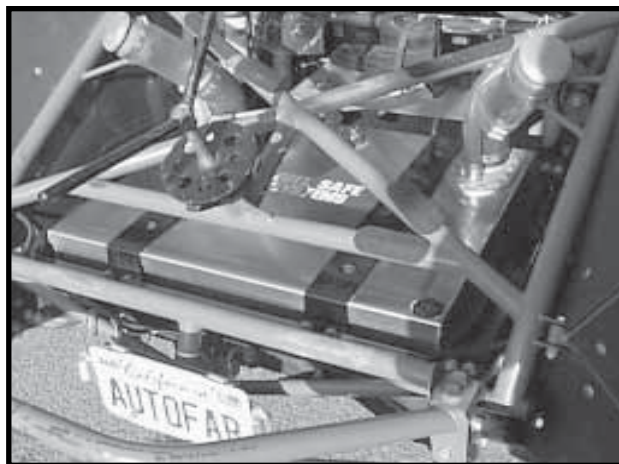
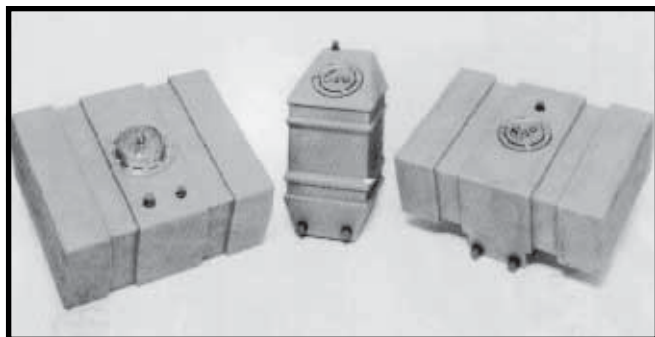

<u>Volume</u>	<u>PART #</u>	<u>LENGTH</u>	<u>WIDTH</u>	<u>HEIGHT</u>
8 gal	RS208	20-3/8"	15-1/4"	7-3/4"
12 gal	RS212	20-1/4"	17-1/2"	9-3/8"
15 gal	RS215	25-5/8"	17-1/2"	9-3/8"
22 gal	RS222A	33-1/2"	17-1/2"	9-1/8"
22 gal	RS222B	24-3/8"	16-1/2"	13-1/4"
25 gal	RS225	25-3/8"	17-1/4"	14-1/8"
32 gal	RS232A	25-3/8"	17-1/4"	18-1/8"
32 gal	RS232B	33-5/8"	17-3/8"	14-1/4"

## STANDARD EQUIPMENT

- Very durable plastic cell
- Full foam baffling
- One 1/2 in. pick-up and one 3/8 in. vent fitting
- 3 in. raised filler neck with a large bail handle cap
- Optional 2-1/4 in. or 3 in. remote plate with roll over valves



10996 N. Woodside Ave.  
Santee California 92071



619-562-1740  
www.autofab.com

# Fuel Cell components



**MULTI LOCATION 6x10  
PLATE**  
Part No.....ML 6x10

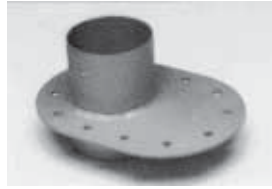

**REMOTE 4x6 FILL PLATE**  
Part No.....RF300 (3")  
Part No.....RF4x6  
(2-1/4")

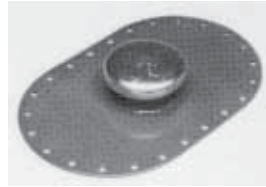

**STANDARD 6x10 FILL  
PLATE**  
Part No.....SF6x10

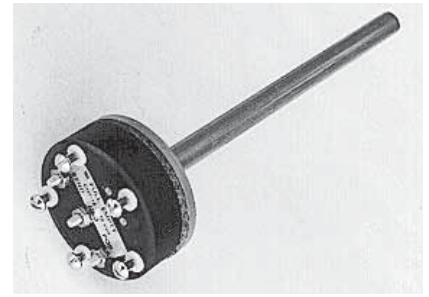

**ELECTRO-MAGNETIC FUEL LEVEL GAUGE**  
Magnetically-coupled fuel level sensors especially designed for fuel cell use. Extremely accurate and durable, this unit is ideal for all applications. (Custom units also available.)  
Sending units  
12" ..... SUO12  
12" electronic can be shortened to 3"  
24" ..... SUO24  
24" electronic can be shortened to 12"

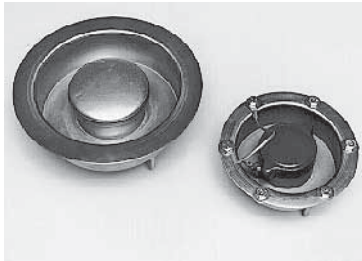

**RECESSED FENDER FILLER**  
2-1/4" and 3" recessed remote fender fillers makes it easier to mount remote location, such as to the fender or deck of car.  
2 1/4" Recessed fender filler RF200, 3" is RF300

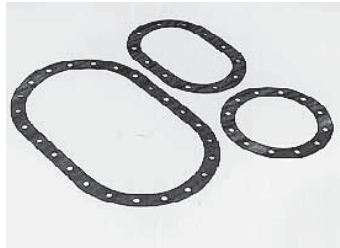

**GASKETS**  
From 4 hole bolt circle to 24 bolt oval.  
24 bolt oval .....OG024  
12 bolt oval .....OG012  
12 bolt circle .....CG012  
10 bolt circle .....CG010  
8 bolt circle .....CG008  
6 bolt circle .....CG006  
4 bolt circle .....CG004



**FILLER NECKS AND CAPS**  
1-3/4" to 3" filler necks and caps to fabricate your own fuel inlet system.  
1-3/4" O.D. filler neck/steel.....FN175  
2-1/4"x7/8" O.D. filler neck/  
steel.....FN225  
3 x 3 O.D. filler neck/steel .....FN300  
1-3/4" filler cap/non vented....FC175  
2-1/4" filler cap/non-vented....FC225  
2-1/4" filler cap/vented ..... FC225V

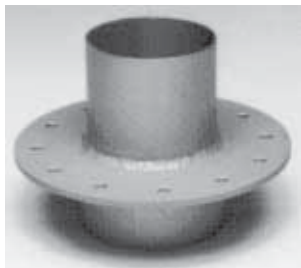

**REMOTE 3" FILL VALVE**  
Part No.....FV390  
Part No.....CTR300-90



**HOSE**  
Filler and vent hoses from 1/4 to 3".  
3" I.D. clear filler hose ..CH300  
2-1/4" I.D. reinforced black filler  
hose .....BH225  
2" I.D. clear filler hose ..CH200  
1" I.D. clear vent hose ..CH100



**3" RUBBER ELBOWS**  
45° and 90° tough rubber elbows for use with 3" remote fill plates.  
45° Elbow.....RE45  
90° Elbow.....RE90



**3" BAIL HANDLE CAP**  
Part No.....CTC300  
*For circle track fuel cells*



**FUEL PICK-UP KIT**  
Includes: 1' Hose, 1' Hose Barb, 1' Filter  
Part No.....FP180 (3/8")  
Part No.....FP181 (1/2")



**REMOTE 2-1/4" FILL  
VALVES**  
45° Rollover Valve.....FV245  
90° Rollover Valve.....FV290



**AIRCRAFT STYLE FLUSH  
CAP**  
Part No.....FV300



**1" IN TANK CHECK VALVE**  
Mounts in bladder or cell. This valve offers positive shut-off.  
Part No.....ITV100



10996 N. Woodside Ave.  
Santee California 92071



619-562-1740  
www.autofab.com

# Mastercraft Racing Seats



RubiconJeep seat



Low-Back Race RD-3  
w/Lumbar Support



Picture of seat skeleton  
with suspension lacing etc.



High-Back Race  
RD-3



**Taylor made**  
the original design Taylor  
made racing seats



3G trophy truck seat

## Autofab Seat Mounts

69-72 Chevy Truck  
73-87 Chevy Truck

73-79 Ford Truck  
80-89 Ford Truck

Designed for Prerunner or Race Seats with Console.

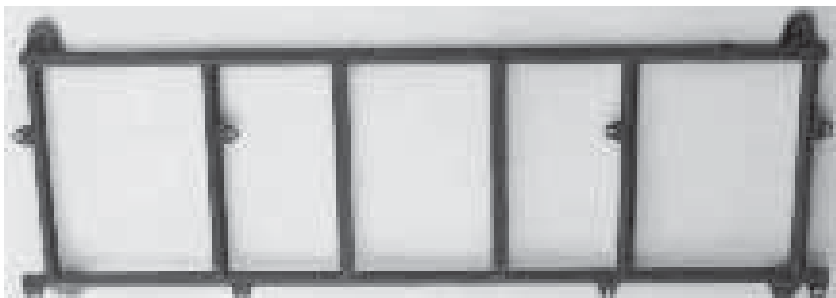

## Padded helmet bag



10996 N. Woodside Ave.  
Santee California 92071



619-562-1740  
www.autofab.com



11-1/2" x 8 x 6  
Door Bag\*



12 x 6 x 2-1/2  
Small Tool Tote



17 x 6 x 2-1/2  
Regular Tool Tote\*

17 x 8 x 3-1/2  
Large Tool Tote\*

**Horse Collars**

Ease the pain on shoulder harness



Roll-Up  
tool kit



**Autofab Limit Straps**  
Specify hole to hole length

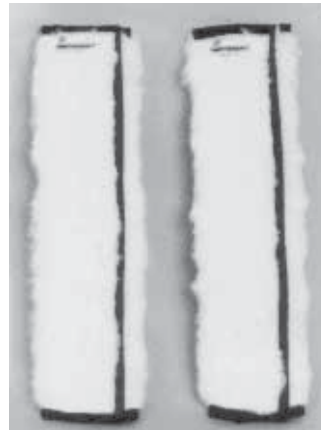

Fuzzy



Vinyl



18 L x 8 Dia.  
Walker Bag - Large Gear Bag w/Carpet Inside

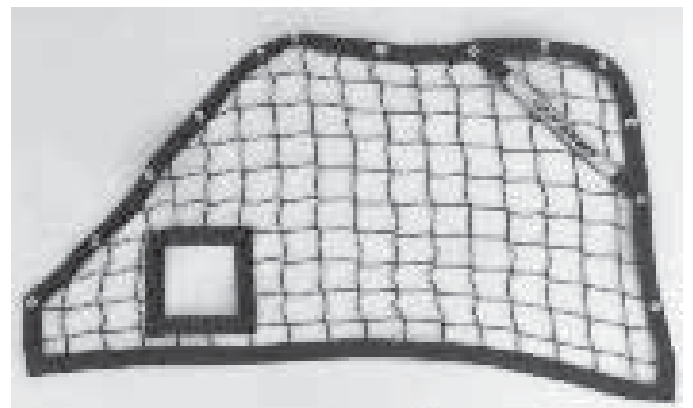

Window Nets



10996 N. Woodside Ave.  
Santee California 92071



619-562-1740  
www.autofab.com

# Urethane Hood Pin Kits

Eliminates stress cracking from fiberglass to metal contact. Each set contains a custom urethane hood pin grommet,  $\frac{9}{16}$ " center pin, locking pin and all mounting hardware.

## HP - 100

R - Red  
W - White  
Bl - Blue  
O - Orange  
Bk - Black  
Y - Yellow

Center Pin **CPIN-100**  
Spring Lock Clip **SPLC-100**  
Urethane Grommet **GROM-100**  
Set of 4 stainless screws w/nuts **SSN-100**  
Spring lock clip w/tether **TETH-100**

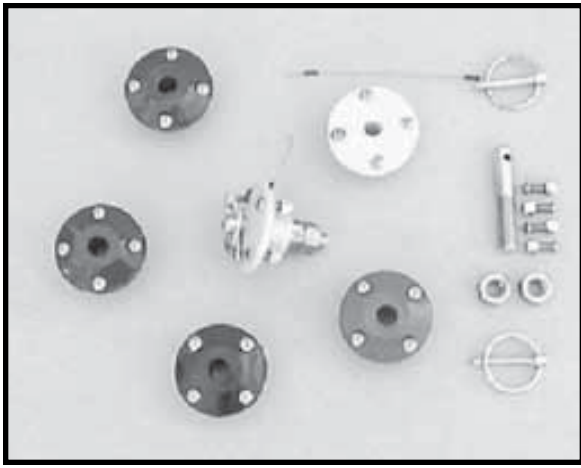

# Urethane Bushing Assemblies

For varied applications from motor mounts and roll cage mounting points to radiator and core supports. All bushing assemblies come complete with two-piece bushing, outer sleeve, inner sleeve and mounting bolt with Nylock nut. **For racing applications, we also offer chromoly outer and inner sleeves and grade eight hardware. Harder bushing compounds are available as well.**

Part No.	Mild Steel Tubing		Mounting Length	Bolt (Grade 5)
	Size	Wall		
BA-200	2"	.120 wall	3"	$\frac{9}{16}$
BA-175	1 $\frac{3}{4}$ "	.120 wall	3"	$\frac{9}{16}$
BA-150	1 $\frac{1}{2}$ "	.120 wall	2 $\frac{1}{4}$ "	$\frac{7}{16}$
BA-125	1 $\frac{1}{4}$ "	.095 wall	2"	$\frac{3}{8}$
BA-100*	1"	.095 wall	1 $\frac{1}{2}$ "	$\frac{3}{8}$

\*No inner sleeve on BA-100

Part No.	Chromoly Steel Tubing		Mounting Length	Bolt (Grade 8)
	Size	Wall		
BA-200CM	2"	.120 wall	3"	$\frac{1}{2}$
BA-175CM	1 $\frac{3}{4}$ "	.120 wall	3"	$\frac{1}{2}$
BA-150CM	1 $\frac{1}{2}$ "	.120 wall	2 $\frac{1}{4}$ "	$\frac{7}{16}$

3/4 .120 CM sleeves on BA200 CM & BA175 CM  
5/8 .090CM sleeves on BA150 CM

## BUSHING HALVES

Two halves needed to make one assembly

B-200            B-175  
B-150            B-125  
B-100



## Killer Bushings

These bushing assemblies are for severe duty locations such as pivots for rear trailing arms etc.

They are made from 2" od .250 wall DOM 3.5" long  
Inside sleeve is 1" od .187 wall DOM 4.5" long ,  
sized for  $\frac{5}{8}$ " or  $\frac{3}{4}$ " bolt

Bushings are made from extra hard compound  
Outer sleeve can be drilled and tapped for grease fitting if lubrication is necessary.

Custom sizing available for these parts



10996 N. Woodside Ave.  
Santee California 92071



619-562-1740  
www.autofab.com



HP100  
universal hood  
pin mounting  
system

Left  
RH105 Hood  
RF106 fenders  
BS202  
Bedsides



Below: the new panel mounting system for fiberglass fenders,bedsides and cab skins. An alternative to expensive Dzus fasteners these new fender mounts isolate the fiberglass from the mounting bracket.

Autofab designed coil inserts are manufactured from a "dead" material for compression rate increase without the "bounce" commonly found in other doughnuts. We recommend filling the coil completely at the ride height of the coil spring. Generally 3 inserts is enough for both springs.

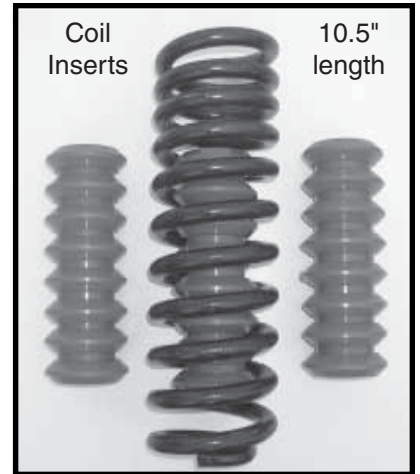

Fender mounting kit

FM100

Panel Mount Grommet

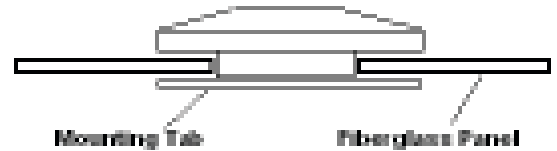

Mounting Tab

Fiberglass Panel



10996 N. Woodside Ave.  
Santee California 92071



619-562-1740  
www.autofab.com

## URETHANE BODY AND CAB MOUNTS

### FORD

66-77	Bronco	6-101
66-77	Hardware Kit	6-102
78-79	Bronco	6-103
83-88	Bronco II, 2wd&4wd	6-104
65-79	4WD Cab Mts (all)	6-105
65-79	2 WD Ford truck (all)	6-110
83-97	Ranger Cab Mts	6-106
80-96	Bronco	6-107
80-96	4WD Ford	6-108
80-96	2 WD Ford	6-109

### TOYOTA ( truck & 4runner )

79-88	4wd pickup cab mts	18-101
84-88	4 Runner body mts	18-102
79-83	2&4wd rear spring kits	18-1001
84-88	2&4wd rear spring kits	18-1002
79-85	all 4wd front spring kits	18-1004
89-95	2wd rear spring kits	18-1005
89-99	all 4wd rear spring kits	18-1006
64-80	FJ40-60 F&R spring kits	18-1003
81-87	front and rear spring kits	18-1007
79-95	2wd front strut kits	18-1201
79-83	2wd C-arm bushings	18-201
84-88	2wd C-arm bushings	18-202
89-95	2wd C-arm bushings	18-205
86-88	4wd C-arm bushings	18-204
89-95	4wd C-arm bushings	18-206

### INTERNATIONAL

72-81	Scout body mts.	9-101
Scout 80 and 800, front and rear springs are the same		
61-68	F or R spring-shackle kits	9-1002
61-68	shackles only for 9-1002	9-802
68-71	with 1 3/16 ID spring eye	9-1003
68-71	shackles only for 9-1003	9-803
Scout II		
72-81	Front or Rear spring kits	9-1001
72-81	shackles only for 9-1001	9-801

**Truck Leaf spring bushings. We stock most rear and front spring applications. Call for part number and current pricing.**



### FORD "C" BUSHING SETS

Vehicle	Year	Offset		
Bronco				
F-100, F150 4WD	66-79	2°	4°	7°
	(4 pcs)	6-1201	6-1202	6-1203
	(14 pcs)	6-1901	6-1902	6-1903
F-100, F150, F-250	66-79	Strut Arm Set		6-1207
	66-79	(Round) Track Arm Set		6-1208
	80-89	Strut Arm Set		6-1209
	76-77	(Oval) Track Arm Set		6-1211
F-350 2WD, 4WD	85-90	Strut Arm Set		6-1209
	85-90	Track Arm Set		6-1212



**Body mount kit for 65-79 Ford 2WD truck. #6-110**

### CHEVY-GM

63-66	Reg Cab only	7-118
67-72	C-10	7-101
73-80	C-10 Truck Only	7-102
67-72	4wd	7-103
73-80	¾ Ton 2wd -4wd	7-104
67-72	K-10 Blazer 4wd	7-105
73-77	K-10 Blazer 4wd	7-106
78-80	K-10 Blazer 4wd	7-107
81-87	C-10, K-10, K-20	7-108
81-90	Crew cab only 2wd/4wd	7-111
88-90	Standard cab 2wd/4wd	7-112
88-90	Extra cab only 2wd/4wd	7-113
81-90	Suburban 2wd/4wd	7-114

### S-series, S10, Blazer etc.

83-99	2wd-4wd Std. Cab	7-115
83-99	2wd-4wd Extra Cab	7-116
83-99	2wd-4wd S10 Blazer	7-117

### JEEP-CJ5,CJ7, WAGONEER, WRANGLER ,TJ etc.

55-73	Jeep 14 pc kit	1-101
74-75	Jeep 18 pc kit	1-109
76-79	CJ 22 pc kit	1-102
80-86	CJ 22 pc kit	1-103
81-86	(CJ8) 26 pc kit	1-104
87-96	Wrangler 22 pc kit	1-105
97-99	TJ etc. 22 pc kit	1-107
67-73	Jeepster-Commando	1-108
63-91	Full size Wagoneer 24pcs	1-106

### DODGE TRUCKS

72-85	D100-W300 cab mts	4-102
72-93	Ramcharger	4-103
79-87	D50-Arrow-Mitsubishi	4-104
87-96	Dakota 2wd	4-105



10996 N. Woodside Ave.  
Santee California 92071



619-562-1740  
www.autofab.com



# Shock Bushings



Part No.	Description	Per Set	Part No.	Description	Per Set
19-901	Shock Mount Stem ended-Style	4	19-909	5/8" ID Standard Straight Eye	2
19-902	Shock Grommet Steering Stabilizer	4	19-915	5/8" ID 1/2 Hourglass Bushing (small)	4
19-903	5/8" ID Hourglass Bushing (small)	2	19-916	3/4" ID 1/2 Hourglass Bushing (small)	4
19-904	3/4" ID Hourglass Bushing (small)	2	19-917	11/16" ID 1/2 Hourglass Bushing (large)	4
19-905	11/16" ID Hourglass Bushing (large)	2	19-918	3/4" ID 1/2 Hourglass Bushing (large)	4
19-906	3/4" ID Hourglass Bushing (large)	2	19-919	KONI (4 Bushings & 2 Sleeves)	6
19-907	5/8" ID Straight Eye (Chrysler)	2	19-920	BILSTEIN (4 Bushings & 2 Sleeves)	6
19-908	3/4" ID Straight Eye (Chrysler)	2			



## CONE & BUTTON STYLE

Part No.	Type	Description	Per Set
19-1315	A	Suspension Bump Stop 11/16 x 1-5/8" Button	2
19-1316	B	Suspension Bump Stop 11/16 x 2" Button	2
19-1317	C	Suspension Bump Stop 1-9/16 x 1-5/8" Cone Type	2
19-1318	D	Suspension Bump Stop 2 x 2-1/8" Cone Type w/Steps	2

## Bump Stops

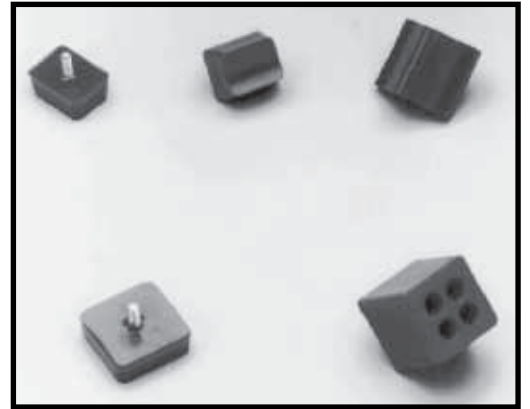

Part No.	Type	Description	Per Set
19-1301	E	Bump Stop 7/8 x 1-3/8"	2
19-1302	F	Bump Stop 1 x 1-3/4 x 1-7/16" (Curved Bottom)	2
19-1303	G	Bump Stop 1-3/8 x 1-1/8 x 1-1/4" (Wedge)	2
19-1304	H	Bump Stop 5/8 x 2 x 2" Square	2
19-1305	I	Bump Stop 2 x 2 x 2" Square	2

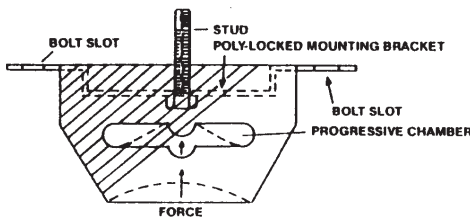

Multi-mount progressive rate suspension stops prevent the damage caused when a suspension bottoms out. Add the energy absorption capabilities of polyurethane to the unique progressive chambers molded into the stops and you've got progressive compression rate bump stops. The multi-mount feature ensures quick, easy retrofitting as one of the mounting systems will be ideal for your particular application. Using a unique poly-lock system, the polyurethane portion and mounting bracket are integrated into one rugged, versatile component. Diagram shows how progressive chamber collapses into itself as force is applied, preventing damage caused by suspension bottoming.

Part No.	Description	Per Set
19-1314	Suspension Bump Stop 1" Multi-Mount	2
19-1306	Suspension Bump Stop 2" Multi-Mount	2
19-1307	Suspension Bump Stop 2-1/2" Multi-Mount	2
19-1308	Suspension Bump Stop 3" Multi-Mount	2
19-1309	Suspension Bump Stop 3-1/2" Multi-Mount	2
19-1310	Suspension Bump Stop 4" Multi-Mount	2
19-1311	Suspension Bump Stop 4-1/2" Multi-Mount	2





- EHF6 Large captive
- EHF5 Small captive
- FB-100 Flat head button
- DB-100 Domed head

## Dzus fasteners

Mount your sheetmetal or fiberglass the trick aircraft way !

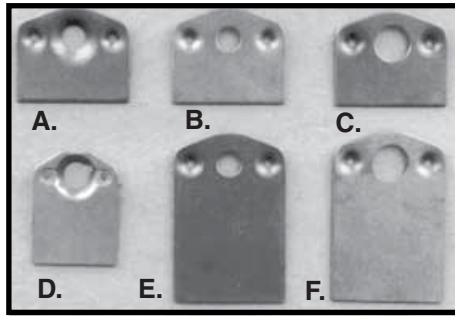

- A. FHP-200 Flat head plate
- B. DHP-100 Domed head plate (short)
- C. LCP-100S EHF6 plate (short)
- D. SCP-200S EHF5 plate (short)
- E. FHP-201 Flat head plate (long)
- F. LCP-200 EHF6 plate (long)

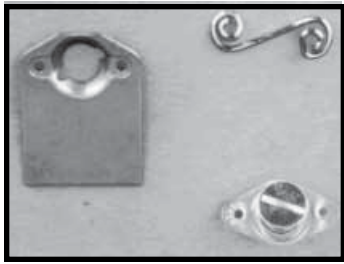

**Small captive dzus kit  
70401**



**Aluminum quick re-  
lease (push button)  
QR-104**

**Steel quick re-  
lease (pin type)  
QR-106**



**Aluminum Wheel  
ST 199-150 (15")  
ST 199-17D (17")**



**Steering Quickener**  
SQ 131-100 1.5 to 1  
SQ 135-100 2.0 to 1

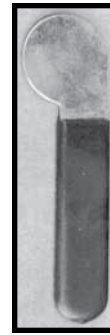

**dzus tool  
ZT-100**

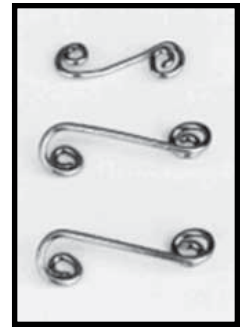

**S6300 flat (fiberglass)  
S6425 offset (sheet metal)  
S6275 small Dzus**

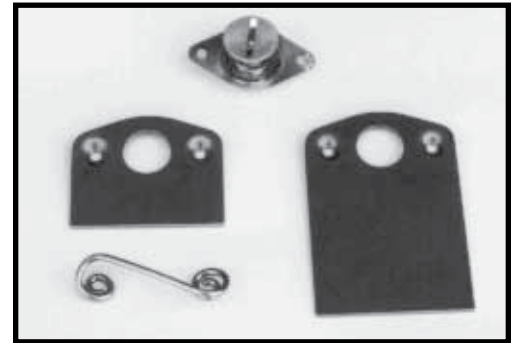

**Large captive dzus kit  
70400  
(Specify long or short plate)**

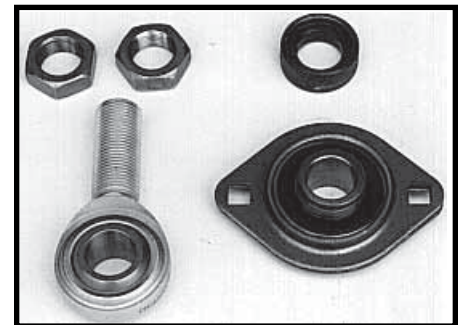

**Steering Heim  
(light duty)  
SH-932xR**

**Steering shaft bear-  
ing (Firewall)  
SSB-990-001**

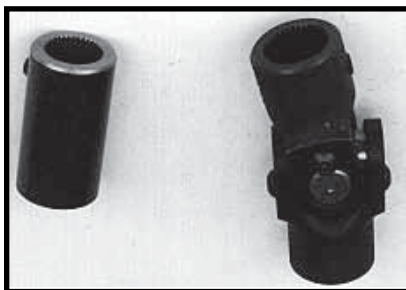

- SJ-110B 3/4 x 3/4
- SJ-113B 3/4 GM man. x 36 spl. (also Ford)
- SJ-114B 13/16 GM pwr. x 36 spl. (big)

- SC117-100 48 spl. 3/4"
- SC117-101 36 spl. GM pair. 3/4"
- SC0117-102 36 spl GM man. 3/4" (also Ford)
- SC117-103 30 spl. GM pwr. 3/4"
- SC117-104 26 spl Ford 3/4"

**Coleman Steering**  
 Quick steer, release and u-joints



**New lightweight  
style**

**Steering Quickener w/shaft  
(13" of 3/4 x .125)**  
SQ 136-100-15 1.5 to 1  
SQ 136-100-20 2.0 to 1



10996 N. Woodside Ave.  
Santee California 92071



619-562-1740  
www.autofab.com

# Steering Box Gusset Kits

## 1973 to 1987 Chevy 4x4 truck, 1992 Blazer and Suburbans

These particular years of straight axle 4x4 trucks are subject to frame cracking problems due to the design and mounting of the factory power steering gearbox combined with lifts and big tires !

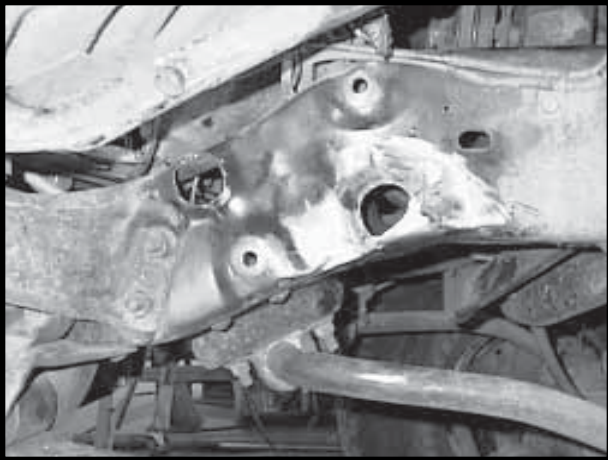
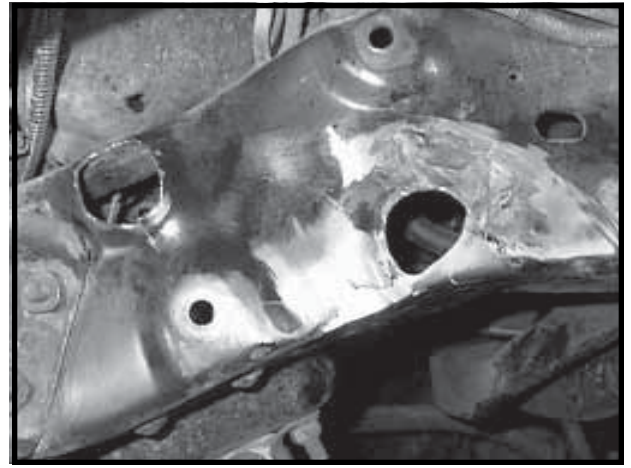

Actual photos of Chevy4x4 frame before repair work completed at Autofab

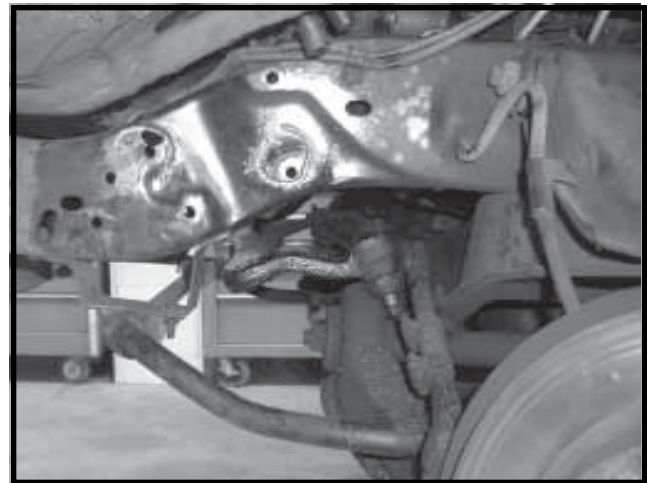

This customers truck had to be towed in because the steering box fell off ! Using the proven Autofab Steering Box Gusset Kit will stop the frame flexing that causes cracks !

The "bolt in" design triangulates the frame to the crossmember with 3 of the steering box mounting bolts. Stop the problem before it starts.

Above picture 1986 2wd Chevy truck. Yes the 2wd trucks will crack the frame wider wheels and tiresmake it worse



**SBGK 100** : 1973 TO 1982 Original design, smaller bracket has one 5/8" hole

**SBGK 200** : 1982 up, mounts behind factory inside corner bracket with 2 hole small bracket

**SBGK 2WD** : 1973 to 1987 truck 2WD, Blazer and Suburban 2wd as well

**RK-4WD** : Rivet replace kit. Consist of grade 8 bolts and nuts for the front crossmember. Stock rivets loosen and cause more frame flex. Bolts can be torqued to properly secure the crossmember

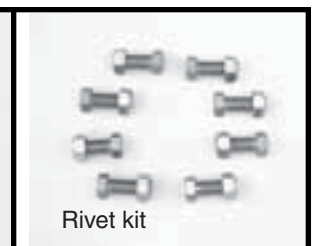

10996 N. Woodside Ave.  
Santee California 92071



619-562-1740  
www.autofab.com

# 1965 to 1979 2wd Ford Truck Off Road Motor Mounts

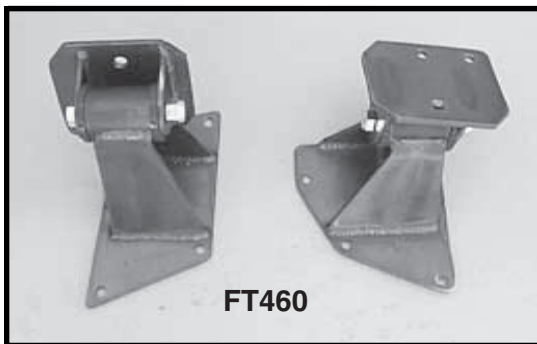

**FT460**

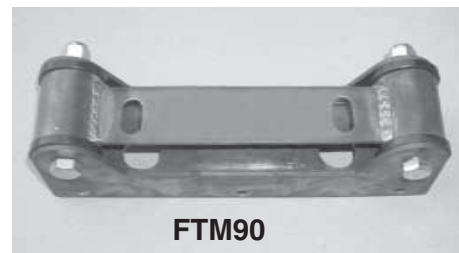

**FTM90**

65-79 2wd trans mount, use with Autofab motor mounts

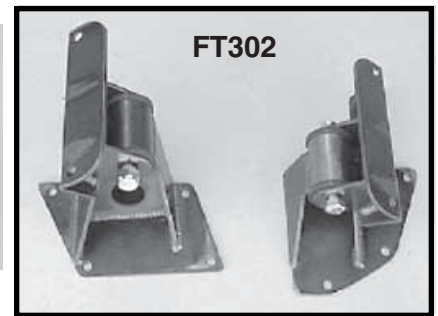

**FT302**

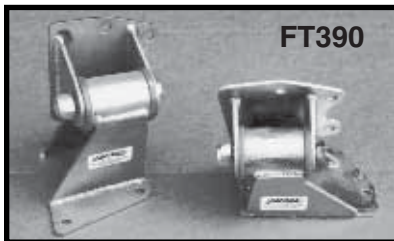

**FT390**

**FT390**  
390-428 FE motor  
65-79 Ford 2wd truck



**FT351**

**FT351**  
351 & 400M motor  
65-79 Ford 2wd trucks



**FT350Chev**

**FT350Chev**  
Chevy V-8 into  
65-79 Ford 2WD trucks

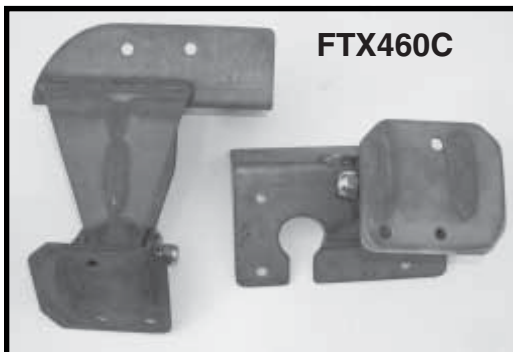

**FTX460C**

**68 to 79 Ford 4x4 Trucks converting to 460 engine**

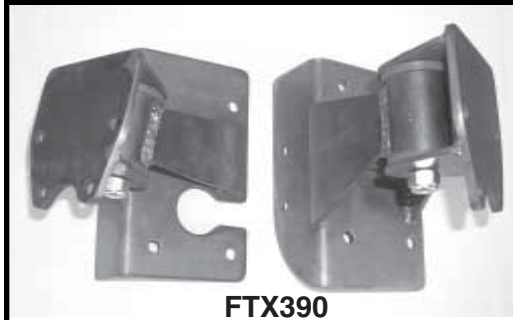

**FTX390**

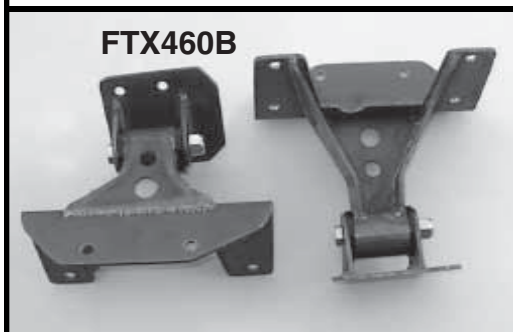

**FTX460B**

**FTX460B**  
78/79 Bronco  
F150 4x4  
460 engine

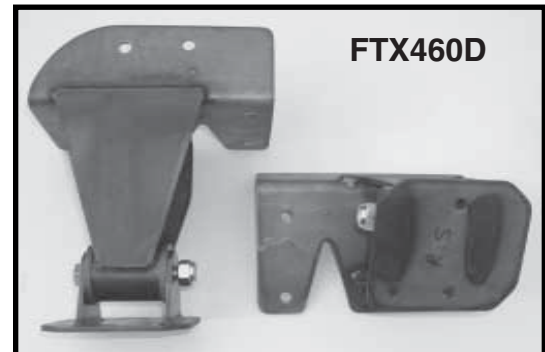

**FTX460D**

**FTX460A**  
78-9 F250/350  
**FTX460B**  
78-9 Bronco/F150

**FTX460C**

68-76 F250

**FTX460D**

68-76F150

**FTX390**

68-76F250

360/390 stock engine

Transmission mount fits most 4x4 trucks, solid style same as motor mounts

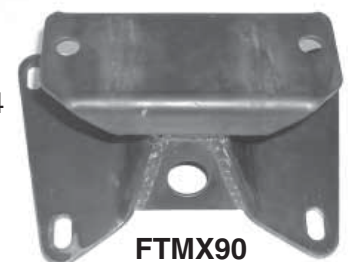

**FTMX90**

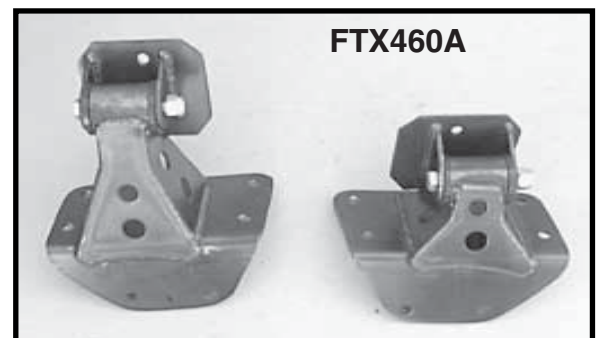

**FTX460A**

**FTX460A**  
78-79 F350  
4wd truck only  
429-460 engine



10996 N. Woodside Ave.  
Santee California 92071



619-562-1740  
www.autofab.com

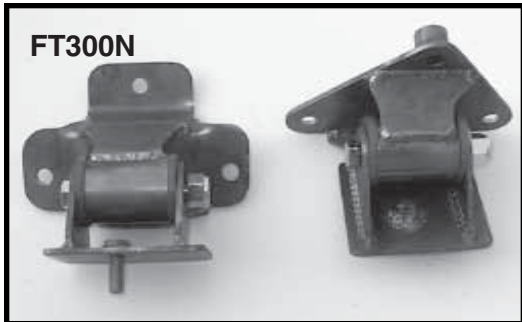

**FT300N**

**FT300N**  
1980-96  
F150 - 6cyl

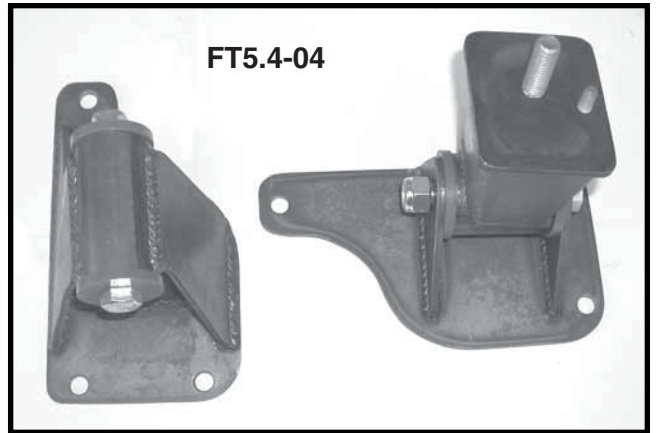

**FT5.4-04**

**04-07 F150 Ford truck**



**FT302N**

**FTM-100**

**FT302N**  
1980 to 96  
Ford Truck-Bronco  
2 wd and 4wd  
302 and 351W



98-03 F150 Lightning w/rear oil filter

**FT5.4-98L**



**FT460N**

**FT460N**  
1980 to 96  
Ford truck-Bronco  
2wd and 4wd  
429-460 engine



**EB-302**

**EB-302**  
302 engine  
mounts  
for the 66-77  
early bronco

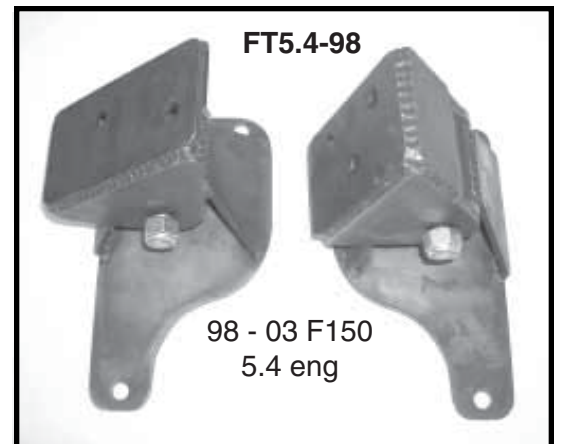

**FT5.4-98**

98 - 03 F150  
5.4 eng



**96-98  
Mustang 4.6DOHC**

Ford Truck-  
Bronco  
transmission  
mount fits all  
2 or 4 WD 85  
up with this  
design  
**FTM-100**



## RANGER SOLID MOTOR MOUNTS

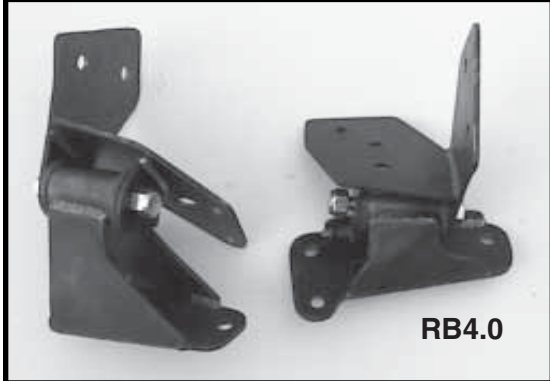
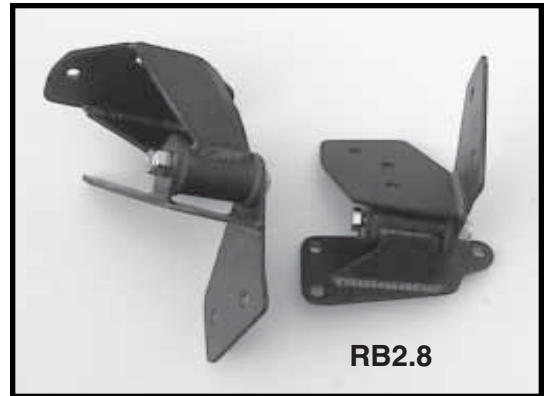
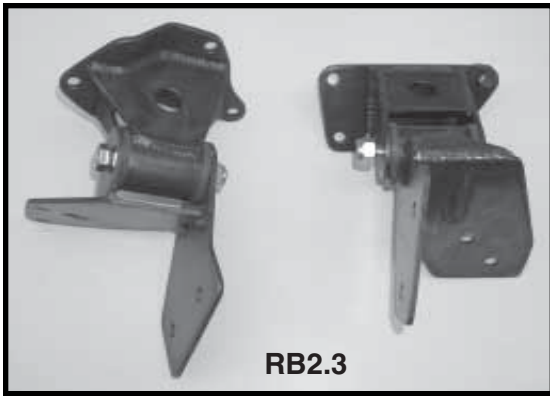

**RB 2.3** - For 1983-1997 Ranger 2wd with 4cyl engine  
**RB 2.8**- for 1983 to 90 Ranger 2wd with 2.8/2.9 V6  
**RB 3.0**- for 1983 to 97 with 3.0 V6 engine  
**RB 4.0**- for 83-97 Ranger 2wd with 4.0 V6 engine  
**RBX 2.9**- for 83 to 90 Ranger 4wd with 2.8/2.9V6  
**RBX 4.0**- for 83 - 97 Ranger 4wd with 4.0V6 engine  
**RA 2.3**- for 98 up 2wd Ranger (coil spring trucks)  
**RA 3.0**- for 98 up Ranger 2wd a/arm truck with 3.0 V6  
**RA 4.0**- 98 up Ranger a/arm 2wd truck with 4.0 V6  
**RAX4.0sohc** - RangerEdge 2or 4wd with 4.0 SOHC eng.  
**RTM100**- transmission mount. Use with all motor mounts

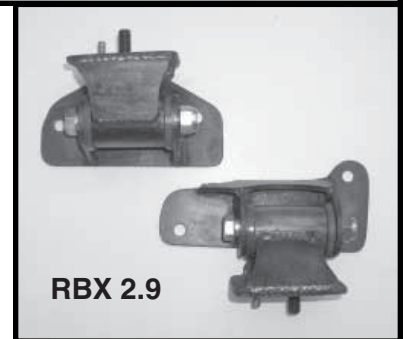
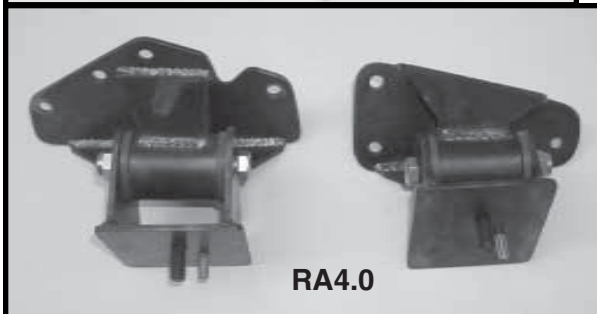
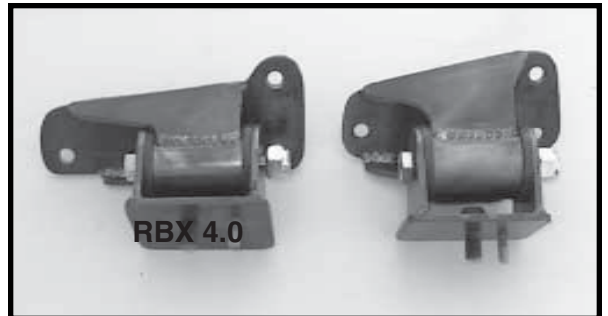
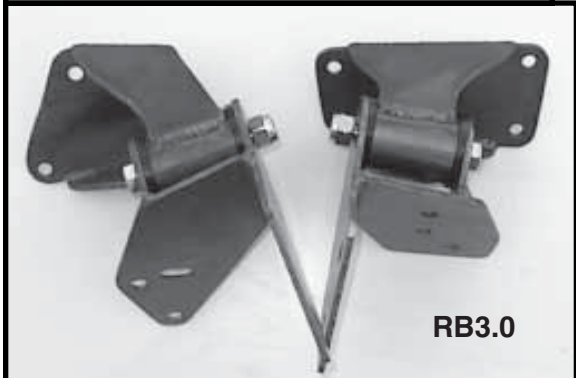

Transmission mount used in all Ranger 2 and 4wd trucks

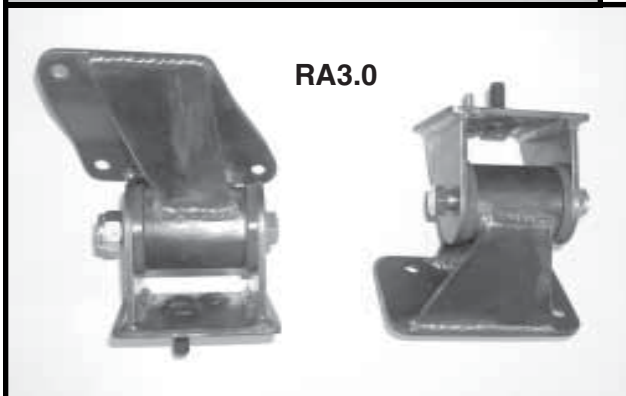

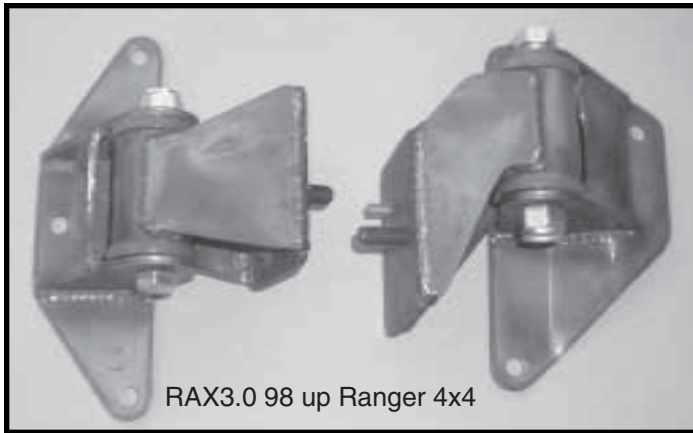

RAX3.0 98 up Ranger 4x4

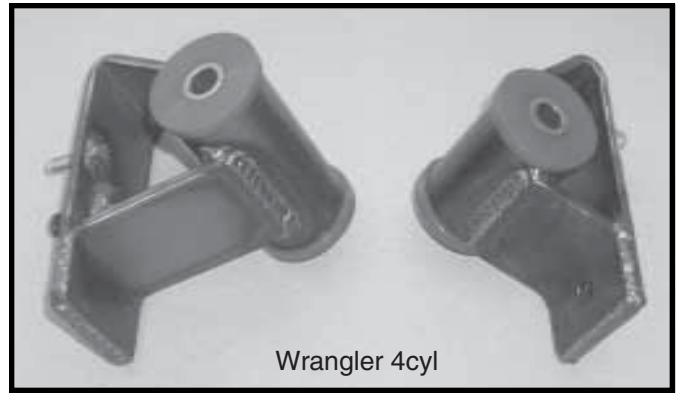

Wrangler 4cyl

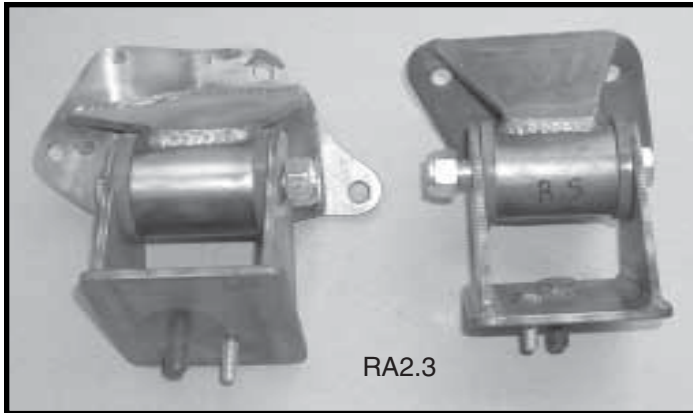

RA2.3

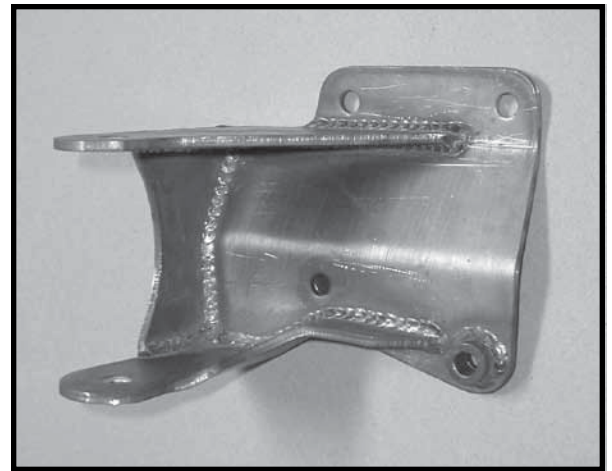

Jeep 4cyl right side motor bracket  
Replace the broken aluminum part no longer available. Bolts in like stock.

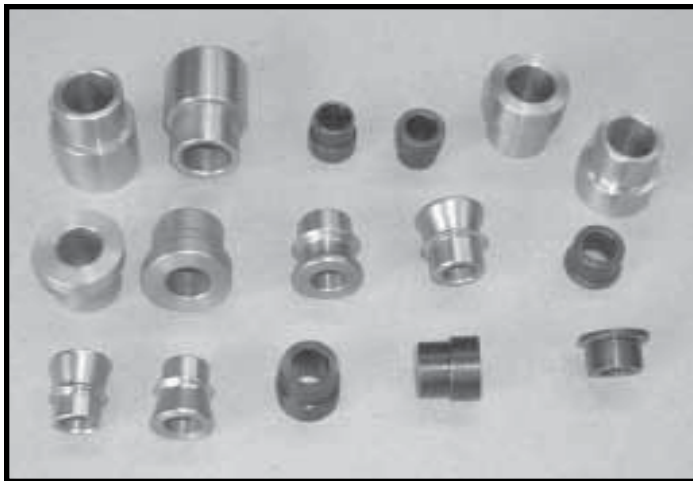

Left: large variety of special reducers and high angle spacers available



Right:  
4130 cups and Mono balls  
CP16 cup  
WBT16 monoball 1"  
CP14 cup  
WBT14 monoball 7/8"

- AM-16** : Large 1 1/4" thread rod ends 4130 alloy steel heat treated high quality Aurora bearings
- S-1.50** : Dom threaded sleeve for 1 1/2" 120 wall tube
- S-1.75** : 4130 threaded weld sleeve for 1 3/4" 120 wall
- S-2.00** : 4130 threaded weld sleeve for 2" 120 wall tube
- LN1.25** : matching jam nut for 1 inch heims
- MM-16** : carbon steel body and race with heat treated alloy steel ball ( prerunner quality )



10996 N. Woodside Ave.  
Santee California 92071



619-562-1740  
www.autofab.com

# Jeep Off Road Motor Mounts

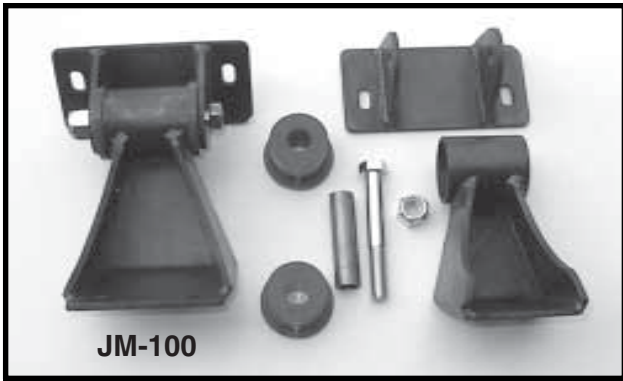

**JM-100**

All CJ with  
258 6cy en-  
gine  
JM-100

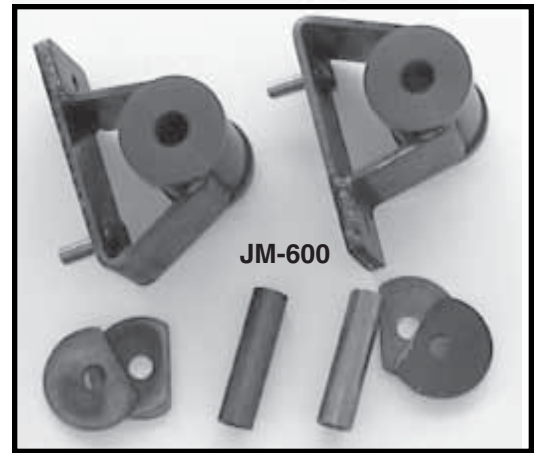

**JM-600**

CJ5-CJ7  
76-86  
Chevy V8  
JM-200



**JM-200**

**JM-600**

New style Wrangler/Cherokee, bullet proof design, bolt in replacement, it is not necessary to remove the cast motor brackets to fit and install these high quality motor mounts. Supplied with special spacers for proper fit and ease of installation! Uses stock metric cross bolt.



**JM-300**

CJ5-CJ7  
with AMC  
304-360  
V8  
JM-300



**JM-700**

**JM-700**  
1993-04 Grand Cherokee with 4.0  
these should be installed with the trans-  
mission mount shown below

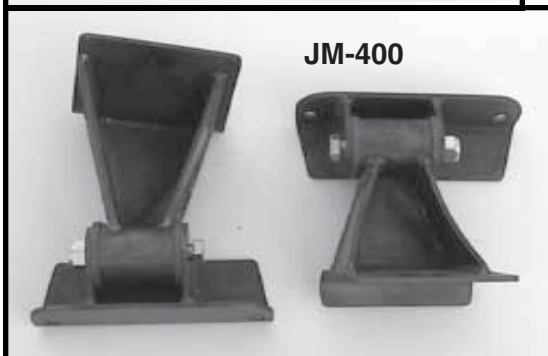

**JM-400**

JM-400  
CJ5-CJ7  
with Ford  
302 V8

**JM-800**

1993-04 Grand Cherokee with V8  
with transmission mount



**JM-500**

JM-500  
wagon and  
honcho  
truck  
with  
360/401  
engine

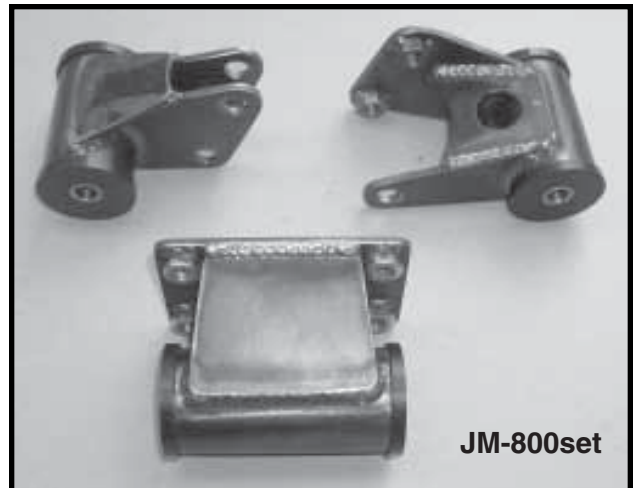

**JM-800set**



10996 N. Woodside Ave.  
Santee California 92071



619-562-1740  
www.autofab.com



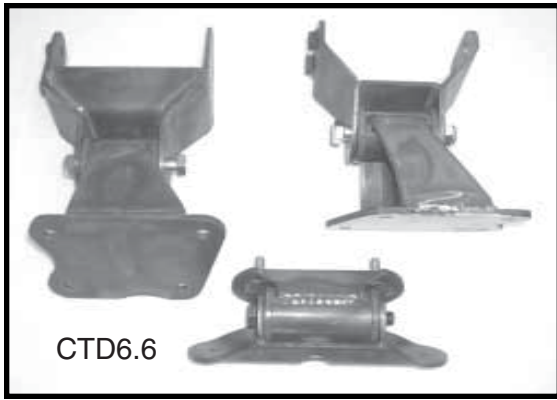

CTD6.6

CT350  
1973 to 87 chevy truck  
2wd and 4wd with  
350 and 454 engine

Left: 2007 Chevy  
6.6 Duramax diesel  
with Allison trans  
CTD6.6



CT350

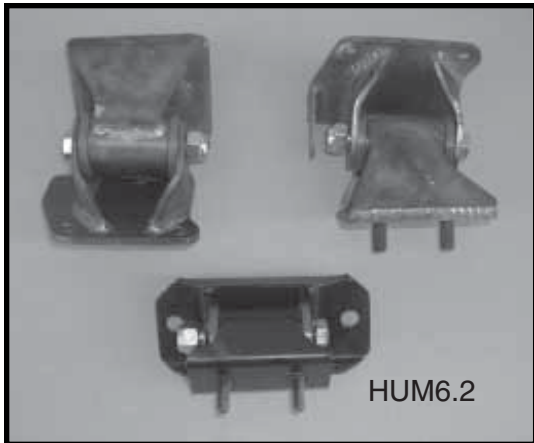

HUM6.2

CT500  
1988 to 98  
Chevy truck with  
350 engine

HUM6.2  
For military Hummers  
6.2 and 6.5 Diesel



CT500



CT454  
1982 up Chevy truck  
with factory big block

Left: UCB350  
universal chevy mount  
350/454 engine  
use for custom mounts

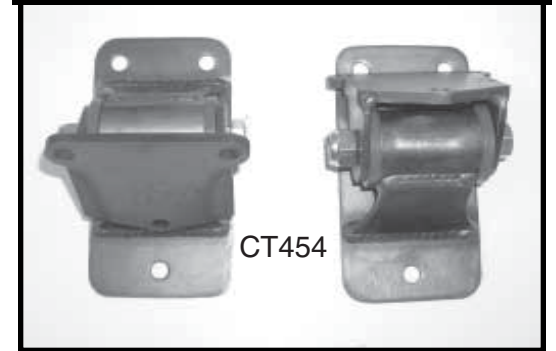

CT454

**V6/V8 into mini truck swaps 2wd only**

- a) 2.8 Ford V6 into Mazda/Courier 74up
- b) 2.8 Ford V6 into Datsun 69 to 80 truck
- c) 3.8 Buick V6 into 72 to 80 Luv truck
- d) 3.8 Buick V6 into Mazda 86 to 92
- e) 3.8 Buick V6 into D50 79 up
- f) 350 chev into S10 early square body 2wd
- g) Chevy V6/V8, Buick V6 to 79up Toyota 2wd
- h) Chevy V8 into 72up Luv trucks



LUV350



TOY350 with headers

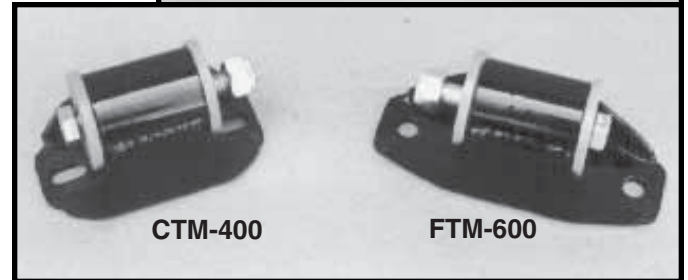

CTM-400

FTM-600

**Chevy Turbo 350-400 and Ford C-6  
Transmission Mounts  
for Custom Applications**



10996 N. Woodside Ave.  
Santee California 92071



619-562-1740  
www.autofab.com

**\* 1/8" TABS \***

Tabs Shown Actual Size



**T101**  
BA-100  
1' radius  
1/8' thick



**T102**  
BA-100  
1 1/4' radius  
1/8' thick

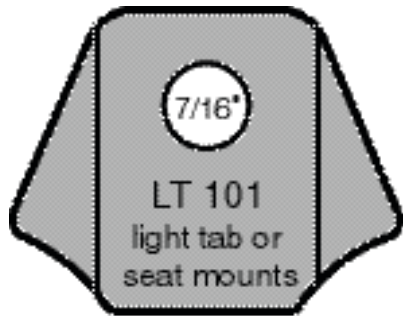

**LT 101**  
light tab or  
seat mounts

1/8' thick

Light tab on left  
available with  
1/4" hole

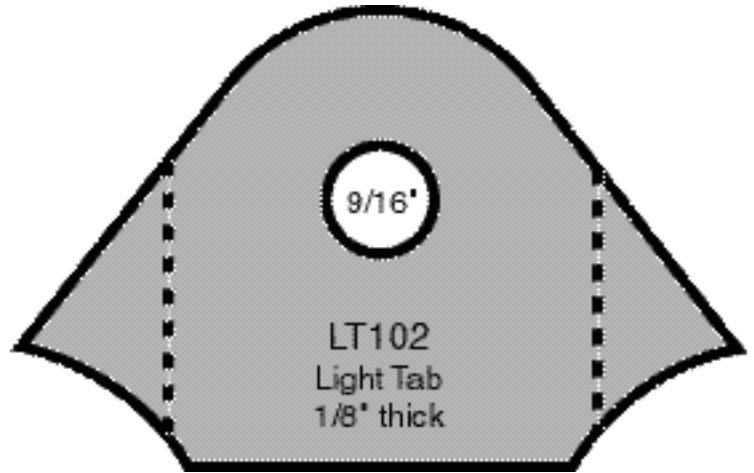

**LT102**  
Light Tab  
1/8' thick



Small tabs on left

From left to right all .090 thick

T75 - 1/4" hole 1.5" tall x 1.5" wide

T65 - 1/4" hole 1.25" tall x 1" wide

T50 - 3/16" hole .75" tall x .75" wide

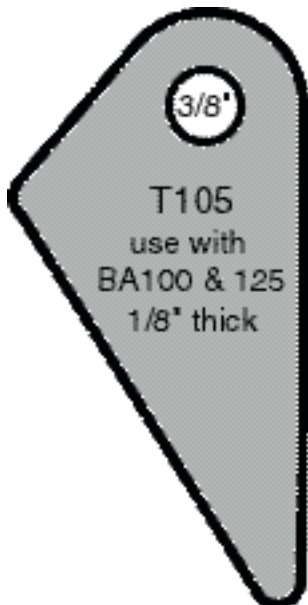

**T105**  
use with  
BA100 & 125  
1/8' thick



**T100L**  
1/8' thick

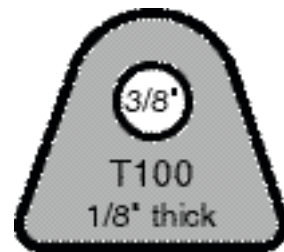

**T100**  
1/8' thick

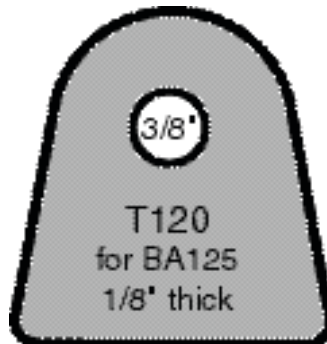

**T120**  
for BA125  
1/8' thick

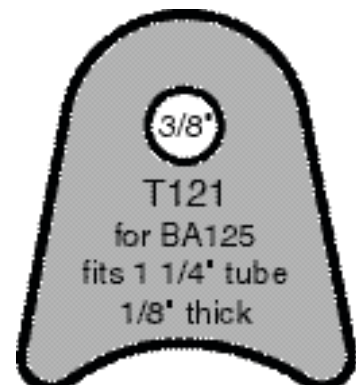

**T121**  
for BA125  
fits 1 1/4' tube  
1/8' thick



10996 N. Woodside Ave.  
Santee California 92071



619-562-1740  
www.autofab.com

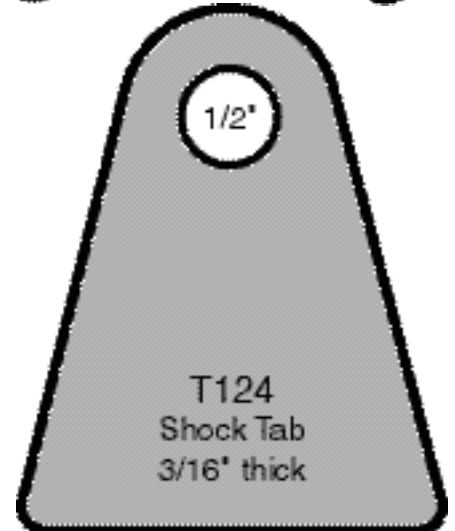
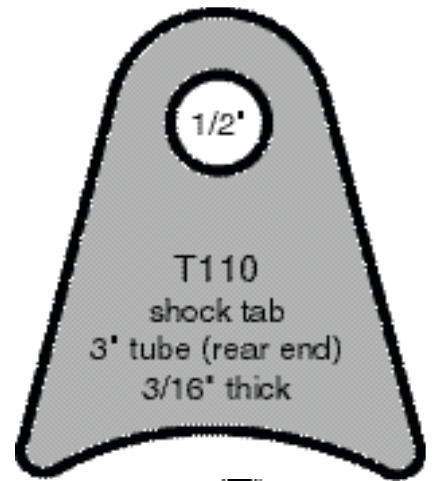
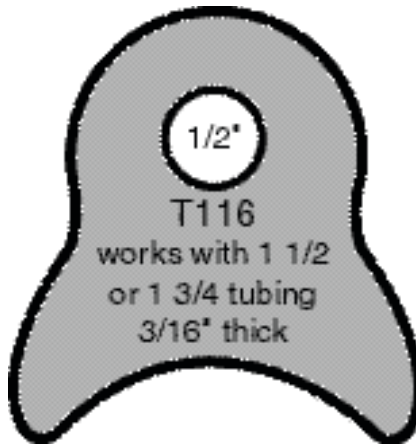
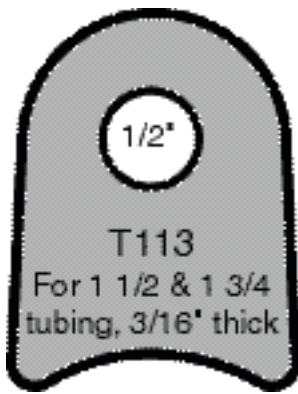

## Shock Tabs

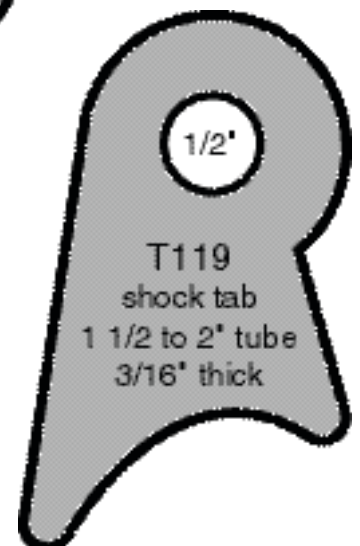
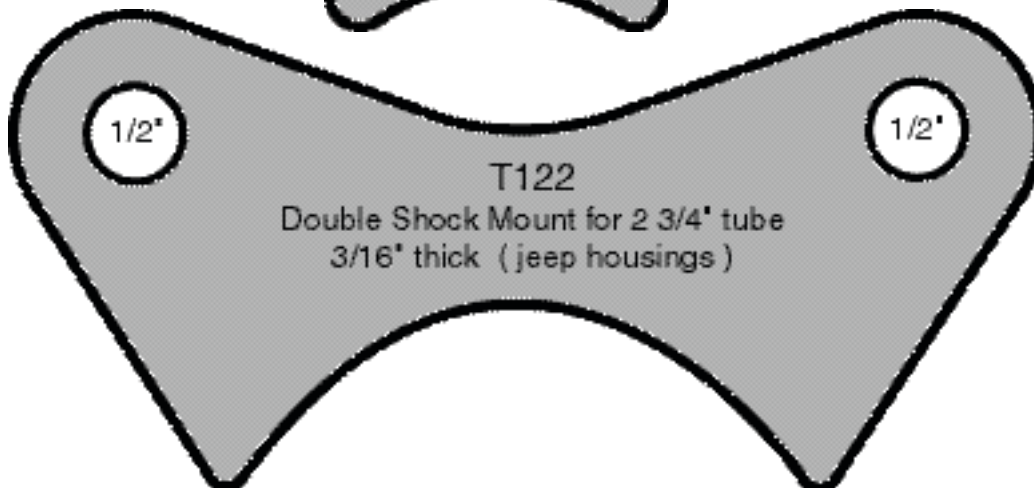
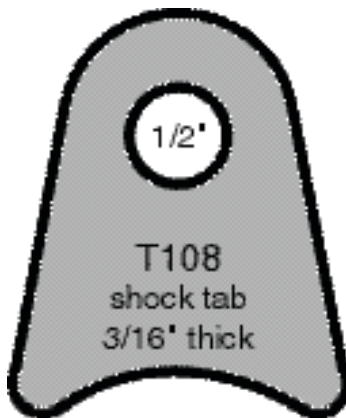

\* **Bushing Tabs** \*

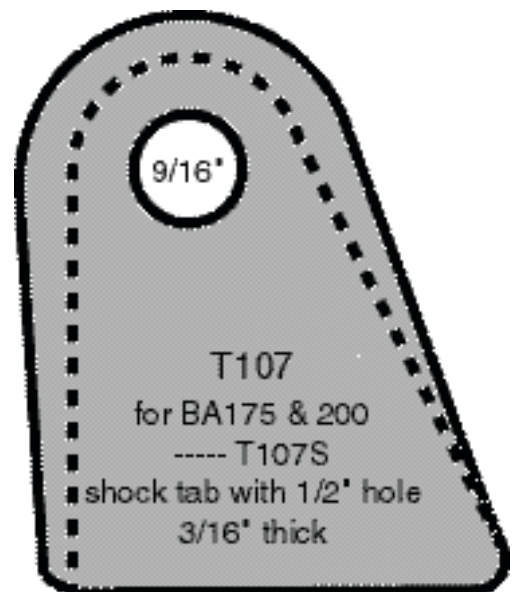
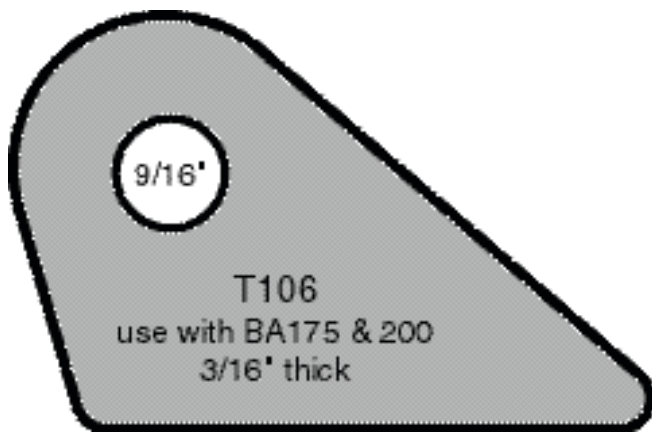
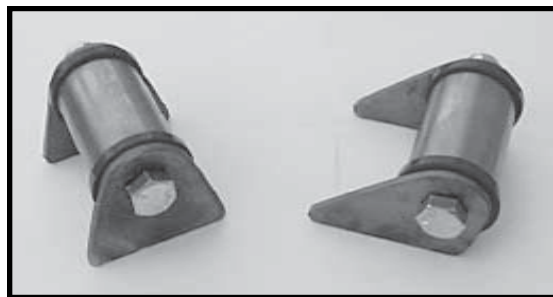
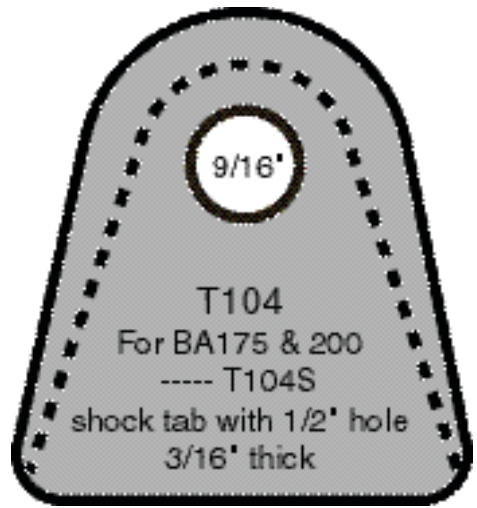
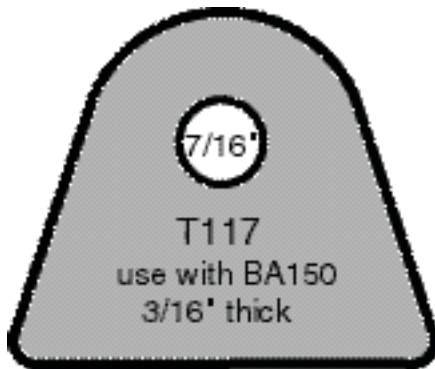
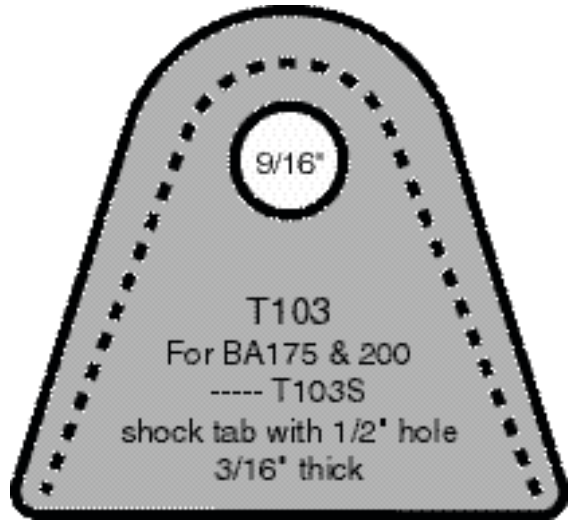

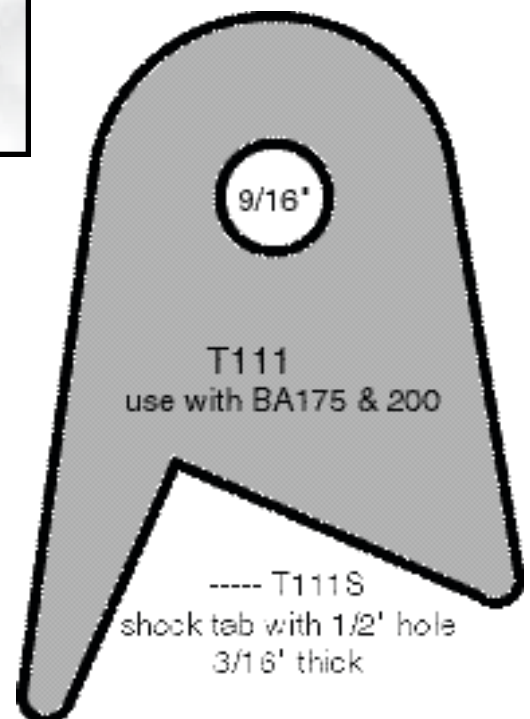
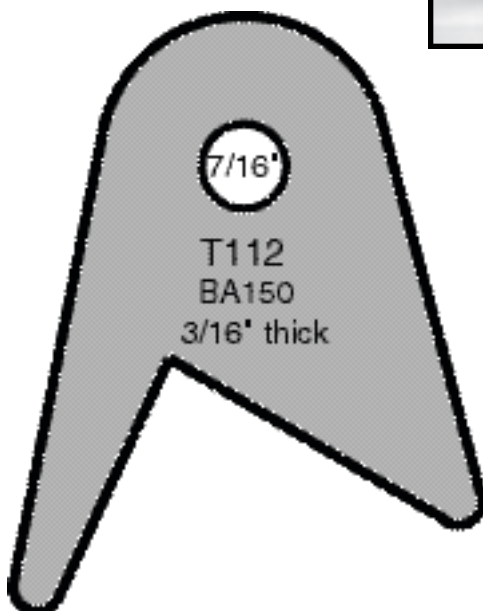
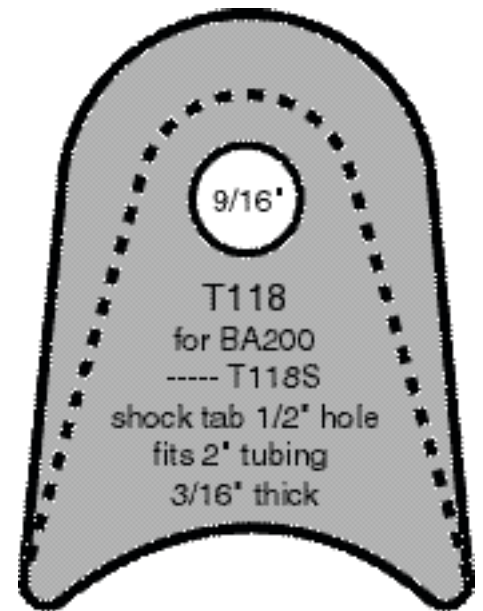
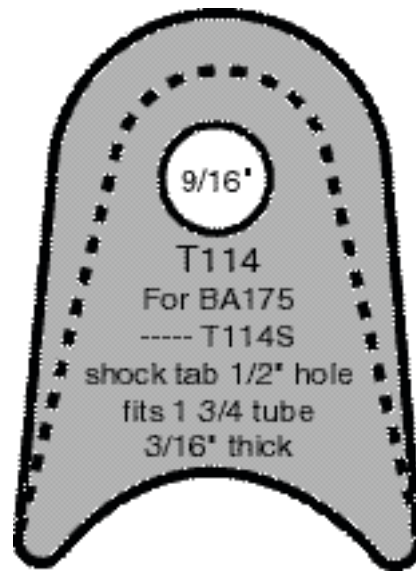
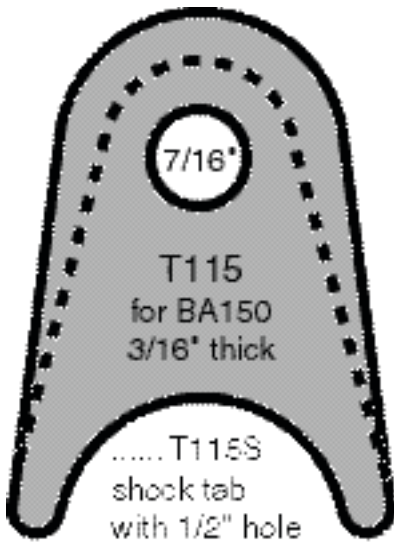

10996 N. Woodside Ave.  
Santee California 92071



619-562-1740  
www.autofab.com



Tube brackets  
designed for our bushing assemblies  
TB200,175,150, and 125

Slash cut tube end mounts  
2.0,1.75,1.5 tubes with 1/2"holes

Under frame brackets  
Setup for BA175 and BA200  
bushing assemblies  
UFB175, UFB200

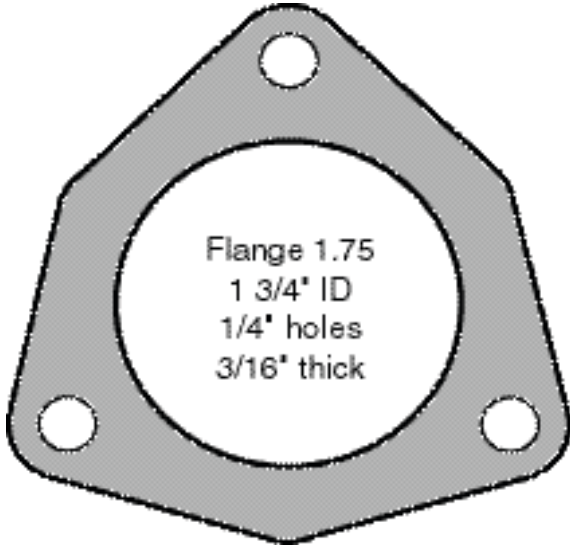

Flange 1.75  
1 3/4" ID  
1/4" holes  
3/16" thick

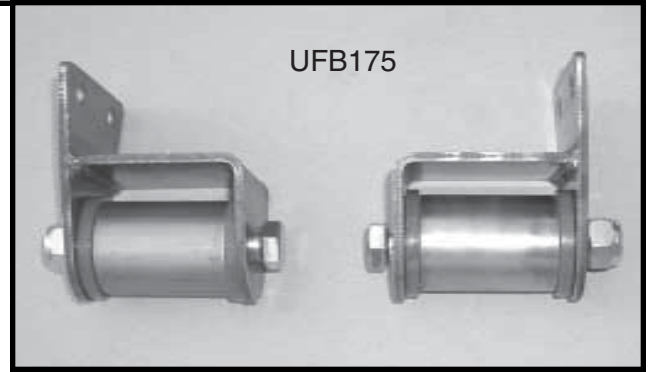

UFB175

3/16" Roll cage gussets L to R  
G105,G90,G90w3h,MG90,  
MG90w1h 1/8" thick,SG

T-125 tab below available 1 inch longer use part  
number T125L  
with 1/2 inch hole and sized for a shock use part  
number T125LS

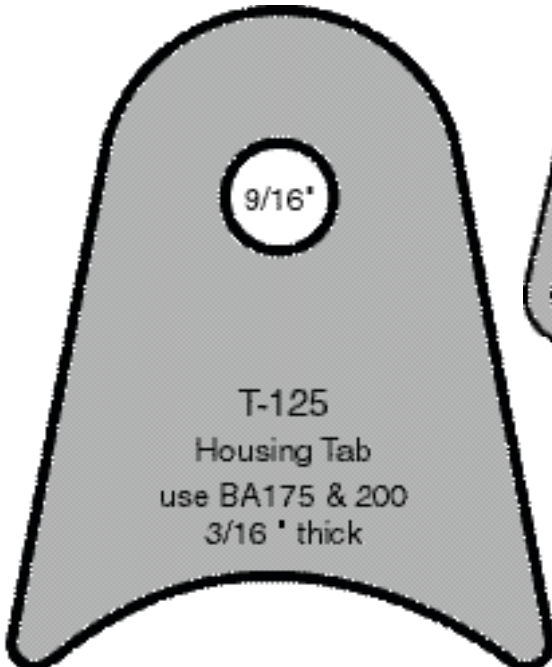

9/16"

T-125  
Housing Tab  
use BA175 & 200  
3/16" thick

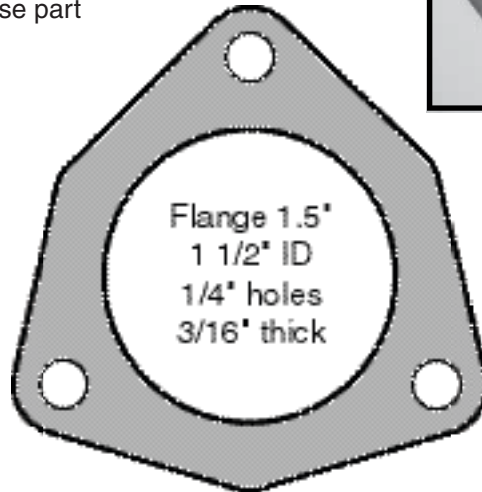

Flange 1.5"  
1 1/2" ID  
1/4" holes  
3/16" thick

T126 tab on right available  
with 1/2 hole for a longer  
shock tab than the T110.  
Use part number **T126S**

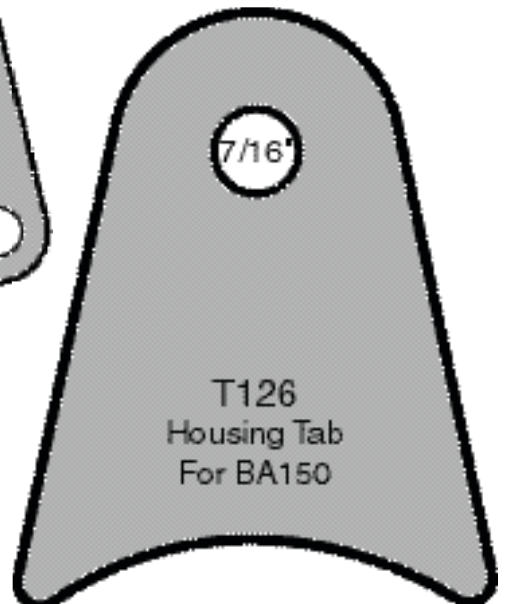

7/16"

T126  
Housing Tab  
For BA150



10996 N. Woodside Ave.  
Santee California 92071



619-562-1740  
www.autofab.com



### BRONCO CAGE MOUNTS

Autofab brackets allow for convenient roll cage mounting to the frame! Utilize urethane body mounts as well to properly locate the body. Saves time and hassle when lining up fiberglass.

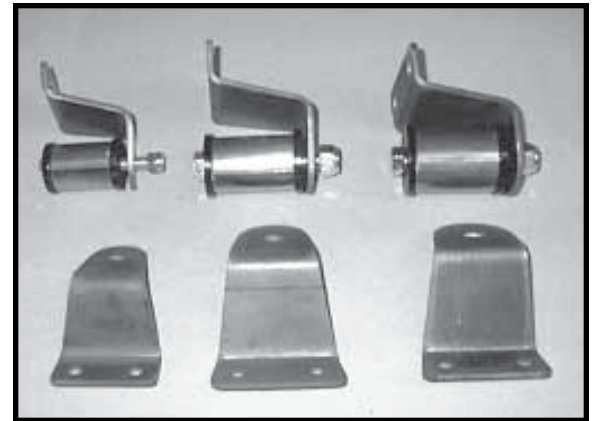

Z brackets above  
 ZB150, ZB175, ZB200  
 Below Flat style bushing mounts  
 BM175,200 BM150, BM125, BM100

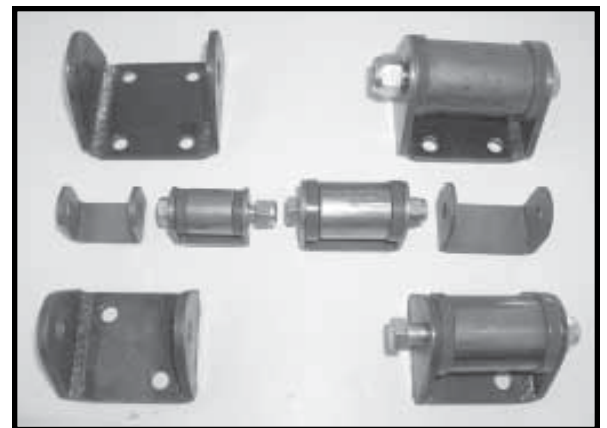

### CAGE MOUNTING BRACKETS

For cab mounts and rear kicker mounts. Designed for use with our 1-3/4" and 2" bushing assemblies. For early and late Ford and Chevrolet trucks.

- A. CMB - 300U** (Universal) Cab mount
- B. CMB - 100F** (67-72 Ford) Rear kicker
- C. CMB - 101F** (73-79 Ford) Rear kicker
- D. CMB - 200C** (Chevy) Rear kicker

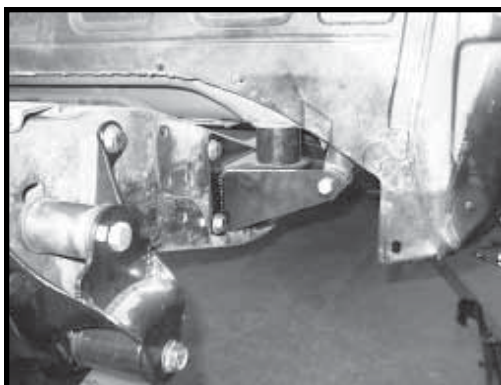
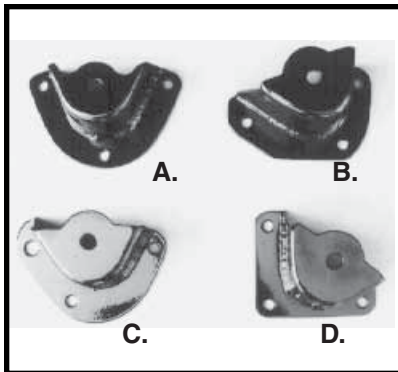

Ranger Cab mount / roll cage bracket. These handy brackets remount the cab and provide a nice way to connect a roll cage to the frame without welding the cage tube to the frame. Now you can lift the cab from the frame for clean workmanship



# AUTOFAB

10996 N. Woodside Ave.  
Santee California 92071  
619-562-1740  
[www.autofab.com](http://www.autofab.com)

